

# VTM™ Transformer

- 48 V to 24 V V•I Chip™ Converter
- 12.5 A (18.8 A for 1 ms)
- High density – 1017 W/in<sup>3</sup>
- Small footprint – 260 W/in<sup>2</sup>
- Low weight – 0.5 oz (15 g)
- Pick & Place / SMD or Through hole
- 125°C operation (T<sub>J</sub>)
- 1 μs transient response
- 3.5 million hours MTBF
- Typical efficiency 96%
- No output filtering required

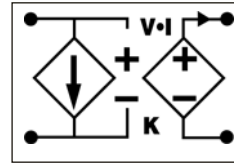

**V<sub>f</sub> = 28 - 53 V**  
**V<sub>OUT</sub> = 13.8 - 26.5 V**  
**I<sub>OUT</sub> = 12.5 A**  
**K = 1/2**  
**R<sub>OUT</sub> = 60.0 mΩ max**



## Product Description

The V048F240T012 V•I Chip transformer excels at speed, density and efficiency to meet the demands of advanced power applications while providing isolation from input to output. It achieves a response time of less than 1 μs and delivers up to 12.5 A in a volume of less than 0.295 in<sup>3</sup> with unprecedented efficiency. It may be paralleled to deliver higher power levels at an output voltage settable from 13.8 to 26.5 Vdc.

The VTM V048F240T012's nominal output voltage is 24 Vdc from a 48 Vdc input Factorized Bus, V<sub>f</sub>, and is controllable from 13.8 to 26.5 Vdc at no load, and from 13.0 to 25.8 Vdc at full load, over a V<sub>f</sub> input range of 28 to 53 Vdc. It can be operated either open- or closed-loop depending on the output regulation needs of the application. Operating open-loop, the output voltage tracks its V<sub>f</sub> input voltage with a transformation ratio, K = 1/2, for applications requiring an isolated output voltage with high efficiency. Closing the loop back to an input PRM™ regulator or DC-DC converter enables tight load regulation.

The 24 V VTM achieves a power density of 1017 W/in<sup>3</sup> in a V•I Chip package compatible with standard pick-and-place and surface mount assembly processes. The VTM's fast dynamic response and low noise eliminate the need for bulk capacitance at the load, substantially increasing system density while improving reliability and decreasing cost.

## Absolute Maximum Ratings

Parameter	Values	Unit	Notes
+In to -In	-1.0 to 60	Vdc	
PC to -In	100	Vdc	For 100 ms
VC to -In	-0.3 to 7.0	Vdc	
VC to -In	-0.3 to 19.0	Vdc	
+Out to -Out	-0.5 to 50	Vdc	
Isolation voltage	2,250	Vdc	Input to output
Output current	12.5	A	Continuous
Peak output current	18.8	A	For 1 ms
Output power	323	W	Continuous
Peak output power	484	W	For 1 ms
Case temperature during reflow <sup>[a]</sup>	225	°C	MSL 5
	245	°C	MSL 6, TOB = 4 hrs
Operating junction temperature <sup>[b]</sup>	-40 to 125	°C	T-Grade
	-55 to 125	°C	M-Grade
Storage temperature	-40 to 125	°C	T-Grade
	-65 to 125	°C	M-Grade

### Notes:

- [a] 245°C reflow capability applies to product with manufacturing date code 1001 and greater.  
 [b] The referenced junction is defined as the semiconductor having the highest temperature. This temperature is monitored by a shutdown comparator.

## Part Numbering

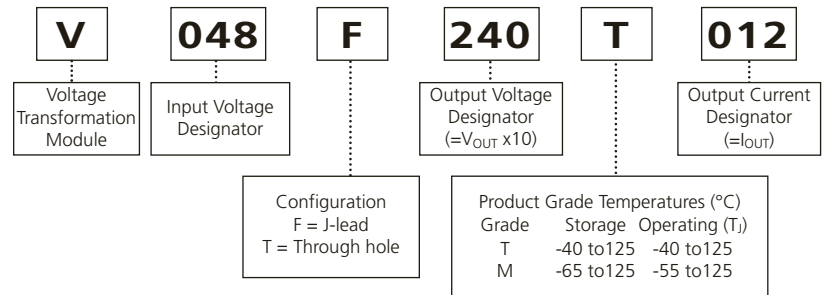

## Electrical Specifications

### Input Specs (Conditions are at 48 V<sub>in</sub>, full load, and 25°C ambient unless otherwise specified)

Parameter	Min	Typ	Max	Unit	Note
Input voltage range	28	48	53	Vdc	Max V <sub>in</sub> = 53 V, operating from -55°C to -40°C
Input dV/dt			1	V/μs	
Input overvoltage turn-on	53.0			Vdc	
Input overvoltage turn-off			57.5	Vdc	
Input current			6.8	Adc	
Input reflected ripple current		120		mA p-p	Using test circuit in Figure 15; See Figure 1
No load power dissipation		4.0	5.9	W	
Internal input capacitance		1.9		μF	
Internal input inductance			5	nH	

### Output Specs (Conditions are at 48 V<sub>in</sub>, full load, and 25°C ambient unless otherwise specified)

Parameter	Min	Typ	Max	Unit	Note
Output voltage	13.8		26.5	Vdc	No load
	13.0		25.8	Vdc	Full load
Rated DC current	0		12.5	Adc	28 - 53 V <sub>IN</sub>
Peak repetitive current			18.8	A	Max pulse width 1ms, max duty cycle 10%, baseline power 50%
Short circuit protection set point	12.8			Adc	Module will shut down
Current share accuracy		5	10	%	See Parallel Operation on Page 9
Efficiency					
Half load	95.0	95.7		%	See Figure 3
Full load	94.7	95.8		%	See Figure 3
Internal output inductance		1.1		nH	
Internal output capacitance		7.7		μF	Effective value
Output overvoltage setpoint	26.5			Vdc	Module will shut down
Output ripple voltage					
No external bypass		150	348	mVp-p	See Figures 2 and 5
3.3 μF bypass capacitor		13		mVp-p	See Figure 6
Effective switching frequency	3.0	3.4	3.8	MHz	Fixed, 1.7 MHz per phase
Line regulation					
K	0.4950	1/2	0.5050		V <sub>OUT</sub> = K•V <sub>IN</sub> at no load
Load regulation					
R <sub>OUT</sub>		43.6	60.0	mΩ	See Figure 16
Transient response					
Voltage overshoot		600		mV	12.5 A load step with 100 μF C <sub>IN</sub> ; See Figures 7 and 8
Response time		200		ns	See Figures 7 and 8
Recovery time		1		μs	See Figures 7 and 8

Waveforms

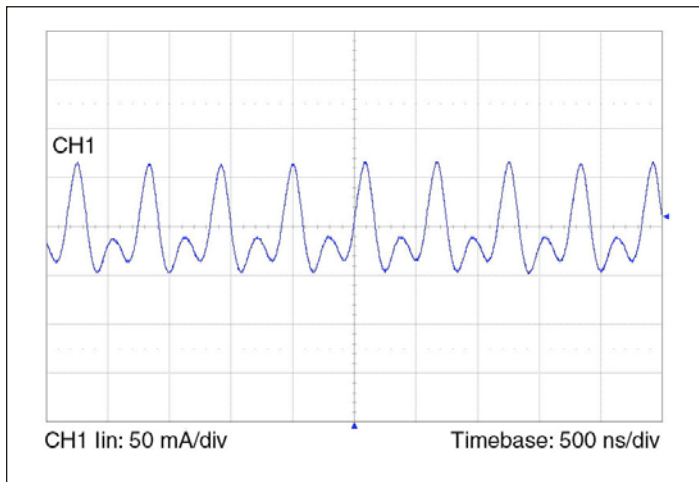

Figure 1 — Input reflected ripple current at full load and 48 Vf.

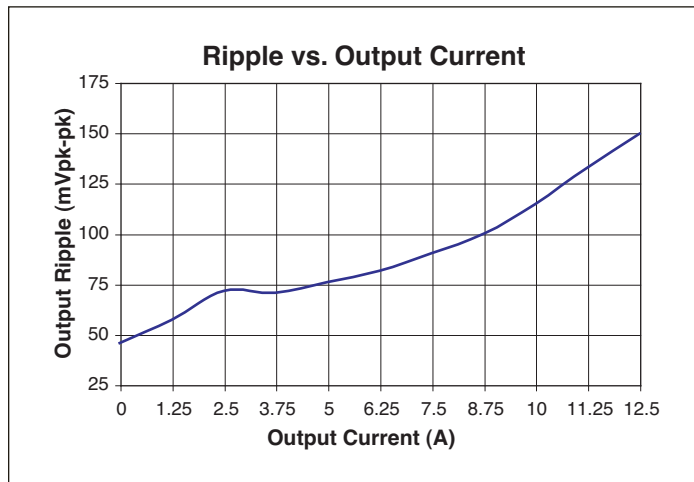

Figure 2 — Output voltage ripple vs. output current at 48 Vf with no POL bypass capacitance.

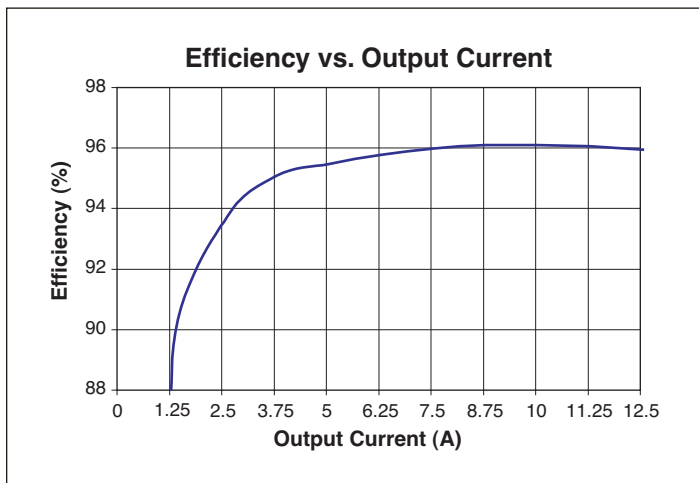

Figure 3 — Efficiency vs. output current.

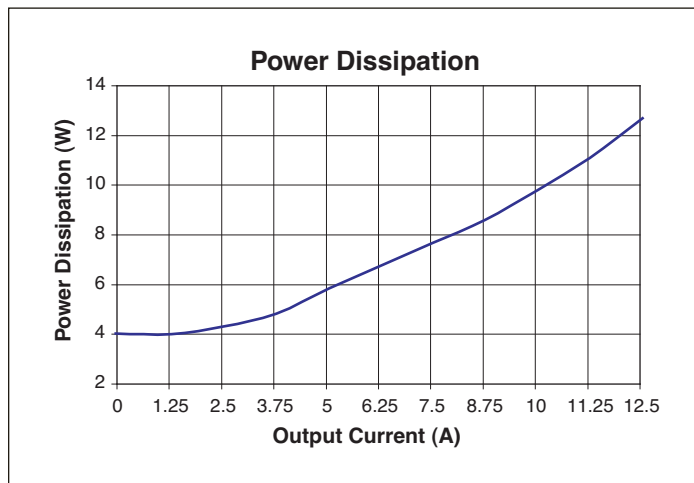

Figure 4 — Power dissipation vs. output current.

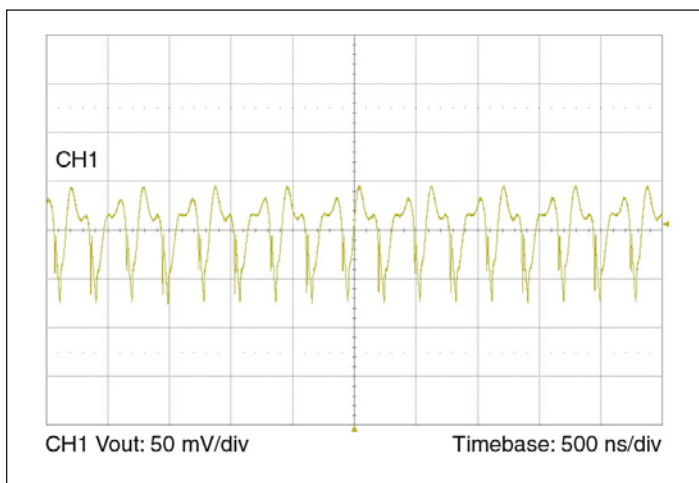

Figure 5 — Output voltage ripple at full load and 48 Vf with no POL bypass capacitance.

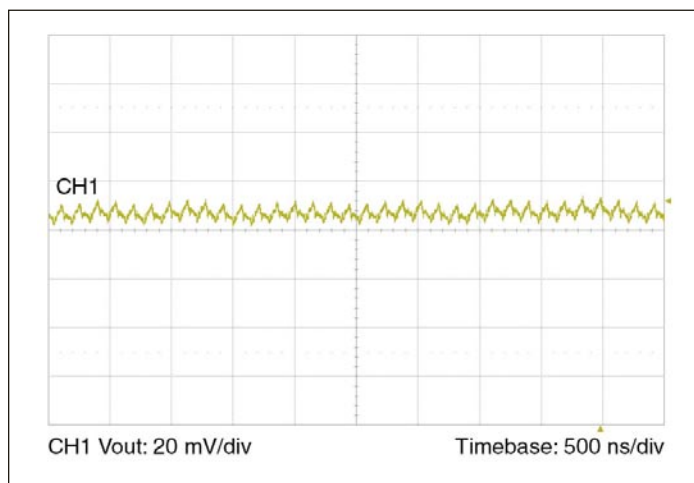
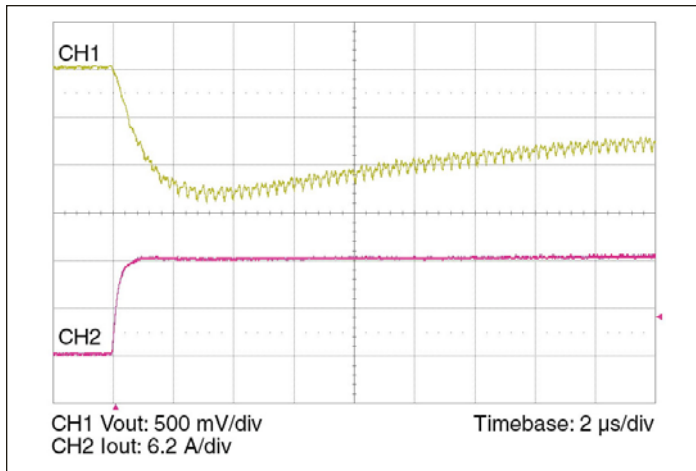
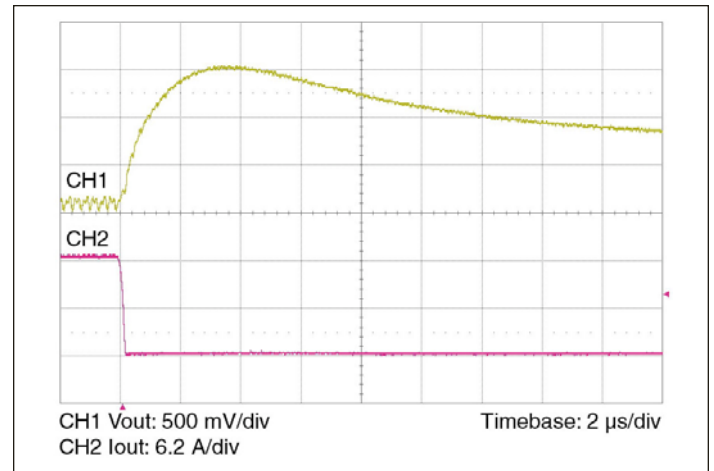

Figure 6 — Output voltage ripple at full load and 48 Vf with 3.3  $\mu$ F ceramic POL bypass capacitance and 20 nH distribution inductance.

## Electrical Specifications (continued)



**Figure 7** — 0-12.5 A load step with 100  $\mu$ F input capacitance and no output capacitance.



**Figure 8** — 12.5-0 A load step with 100  $\mu$ F input capacitance and no output capacitance.

## General

Parameter	Min	Typ	Max	Unit	Note
MTBF					
MIL-HDBK-217F		3.5		Mhrs	25°C, GB
Isolation specifications					
Voltage	2,250			Vdc	Input to output
Capacitance		3,000		pF	Input to output
Resistance	10			M $\Omega$	Input to output
Agency approvals					
		cTÜVus			UL/CSA 60950-1, EN 60950-1
		CE Mark			Low voltage directive
		RoHS			
Mechanical					
Weight		0.53/15		oz/g	See Mechanical Drawings, Figures 10 – 13
Dimensions					
Length		1.28/32,5		in/mm	
Width		0.87/22		in/mm	
Height		0.265/6,73		in/mm	
Peak compressive force applied to case (Z axis)		5	6	lbs.	Supported by J-leads only
Thermal					
Over temperature shutdown	125	130	135	°C	Junction temperature
Thermal capacity		9.3		Ws/°C	
Junction-to-case thermal impedance ( $R_{\theta JC}$ )		1.1		°C/W	See Thermal Considerations on Page 9
Junction-to-board thermal impedance ( $R_{\theta JB}$ )		2.1		°C/W	

## Auxiliary Pins (Conditions are at 48 Vin, full load, and 25°C ambient unless otherwise specified)

Parameter	Min	Typ	Max	Unit	Note
Primary Control (PC)					
DC voltage	4.8	5.0	5.2	Vdc	
Module disable voltage	2.4	2.5		Vdc	
Module enable voltage		2.5	2.6	Vdc	VC voltage must be applied when module is enabled using PC
Current limit	2.4	2.5	2.9	mA	Source only
Disable delay time		20		$\mu$ s	PC low to Vout low
VTM Control (VC)					
External boost voltage	12	14	19	Vdc	Required for VTM start up without PRM
External boost duration		10		ms	Maximum duration of VC pulse = 20 ms

## Pin / Control Functions

### +In / -In DC Voltage Ports

The VTM input should be connected to the PRM output terminals. Given that both the PRM and VTM have high switching frequencies, it is often good practice to use a series inductor to limit high frequency currents between the PRM output and VTM input capacitors. The input voltage should not exceed the maximum specified. If the input voltage exceeds the overvoltage turn-off, the VTM will shutdown. The VTM does not have internal input reverse polarity protection. Adding a properly sized diode in series with the positive input or a fused reverse-shunt diode will provide reverse polarity protection.

### TM – For Factory Use Only

### VC – VTM Control

The VC port is multiplexed. It receives the initial  $V_{CC}$  voltage from an upstream PRM, synchronizing the output rise of the VTM with the output rise of the PRM. Additionally, the VC port provides feedback to the PRM to compensate for the VTM output resistance. In typical applications using VTMs powered from PRMs, the PRM's VC port should be connected to the VTM VC port.

The VC port is not intended to be used to supply  $V_{CC}$  voltage to the VTM for extended periods of time. If VC is being supplied from a source other than the PRM, the voltage should be removed after 20 ms.

### PC – Primary Control

The Primary Control (PC) port is a multifunction port for controlling the VTM as follows:

**Disable** – If PC is left floating, the VTM output is enabled. To disable the output, the PC port must be pulled lower than 2.4 V, referenced to -In. Optocouplers, open collector transistors or relays can be used to control the PC port. Once disabled, 14 V must be re-applied to the VC port to restart the VTM.

**Primary Auxiliary Supply** – The PC port can source up to 2.4 mA at 5 Vdc.

### +Out / -Out DC Voltage Output Ports

The output and output return are through two sets of contact locations. The respective +Out and -Out groups must be connected in parallel with as low an interconnect resistance as possible. Within the specified input voltage range, the Level 1 DC behavioral model shown in Figure 16 defines the output voltage of the VTM. The current source capability of the VTM is shown in the specification table.

To take full advantage of the VTM, the user should note the low output impedance of the device. The low output impedance provides fast transient response without the need for bulk POL capacitance. Limited-life electrolytic capacitors required with conventional converters can be reduced or even eliminated, saving cost and valuable board real estate.

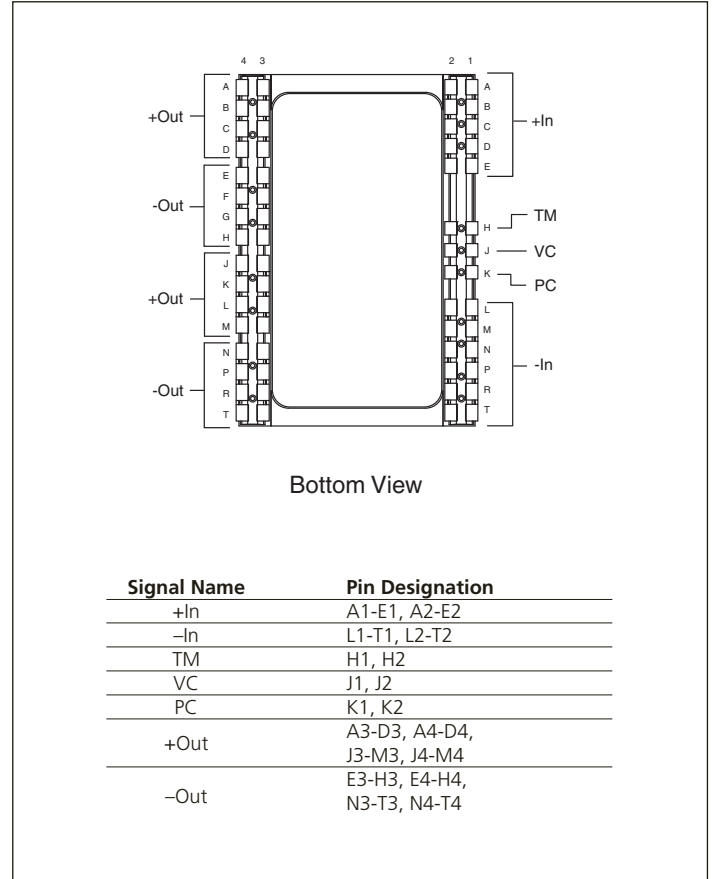

Figure 9 — VTM pin configuration

# Mechanical Drawings

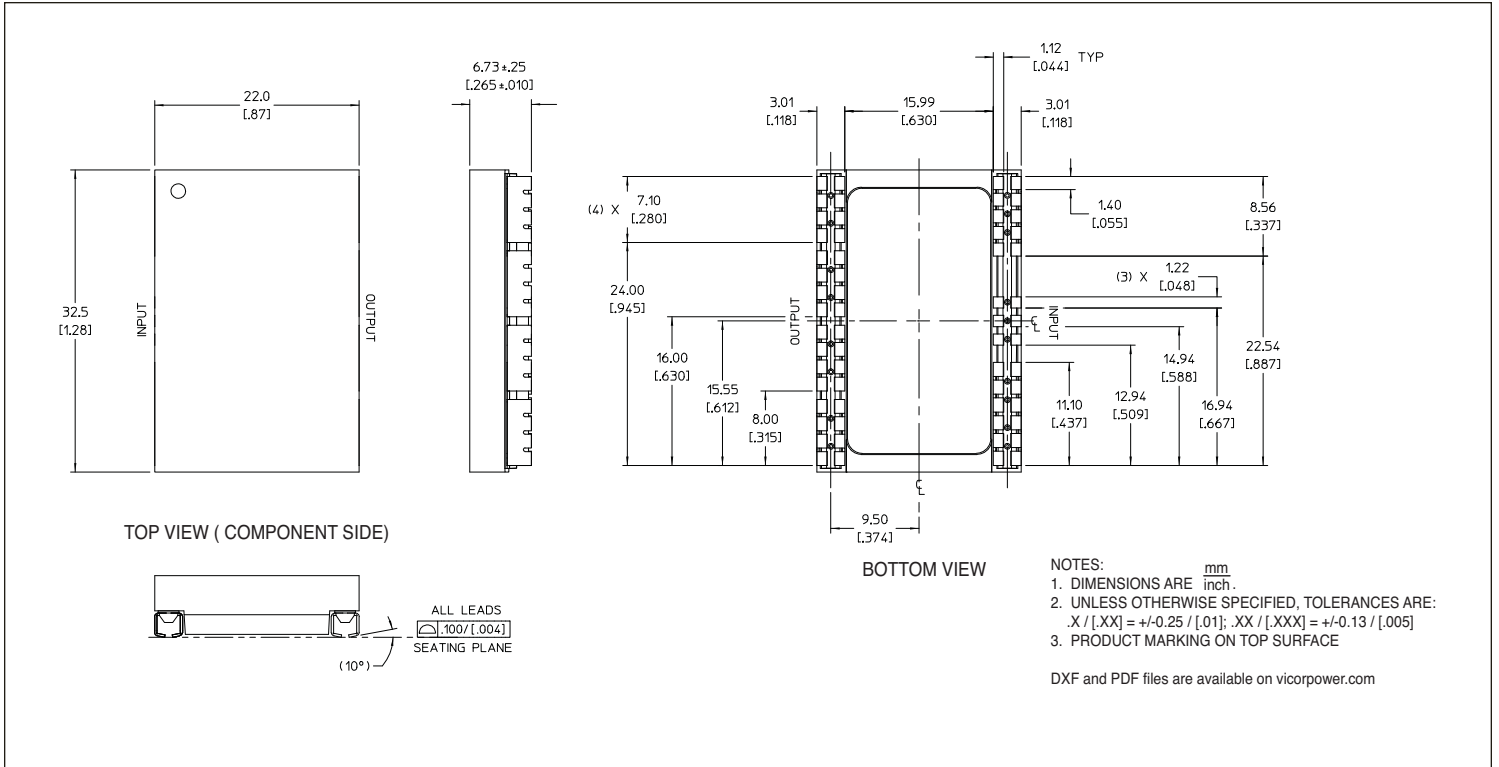

Figure 10 — VTM J-Lead mechanical outline; Onboard mounting

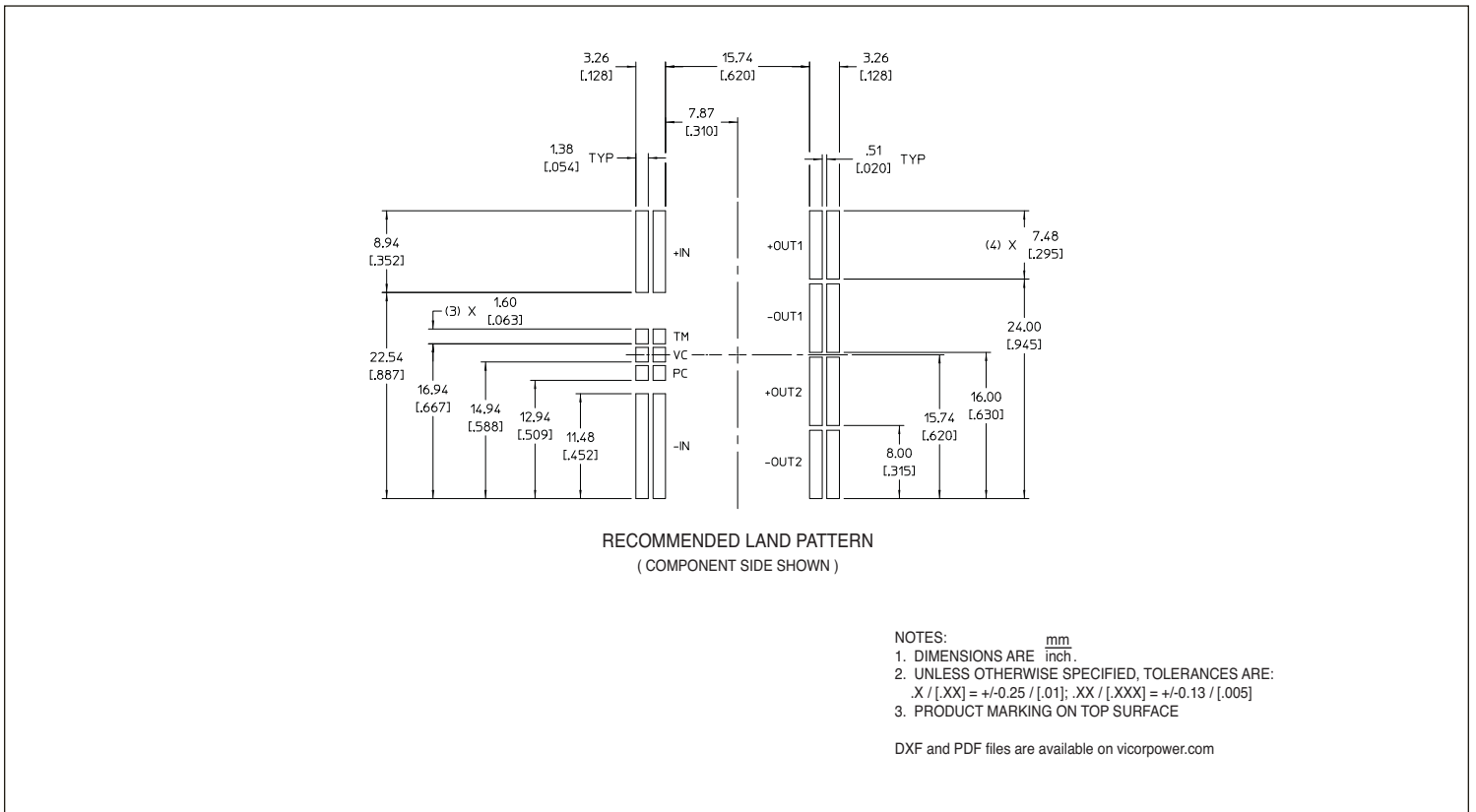

Figure 11 — VTM J-Lead PCB land layout information; Onboard mounting

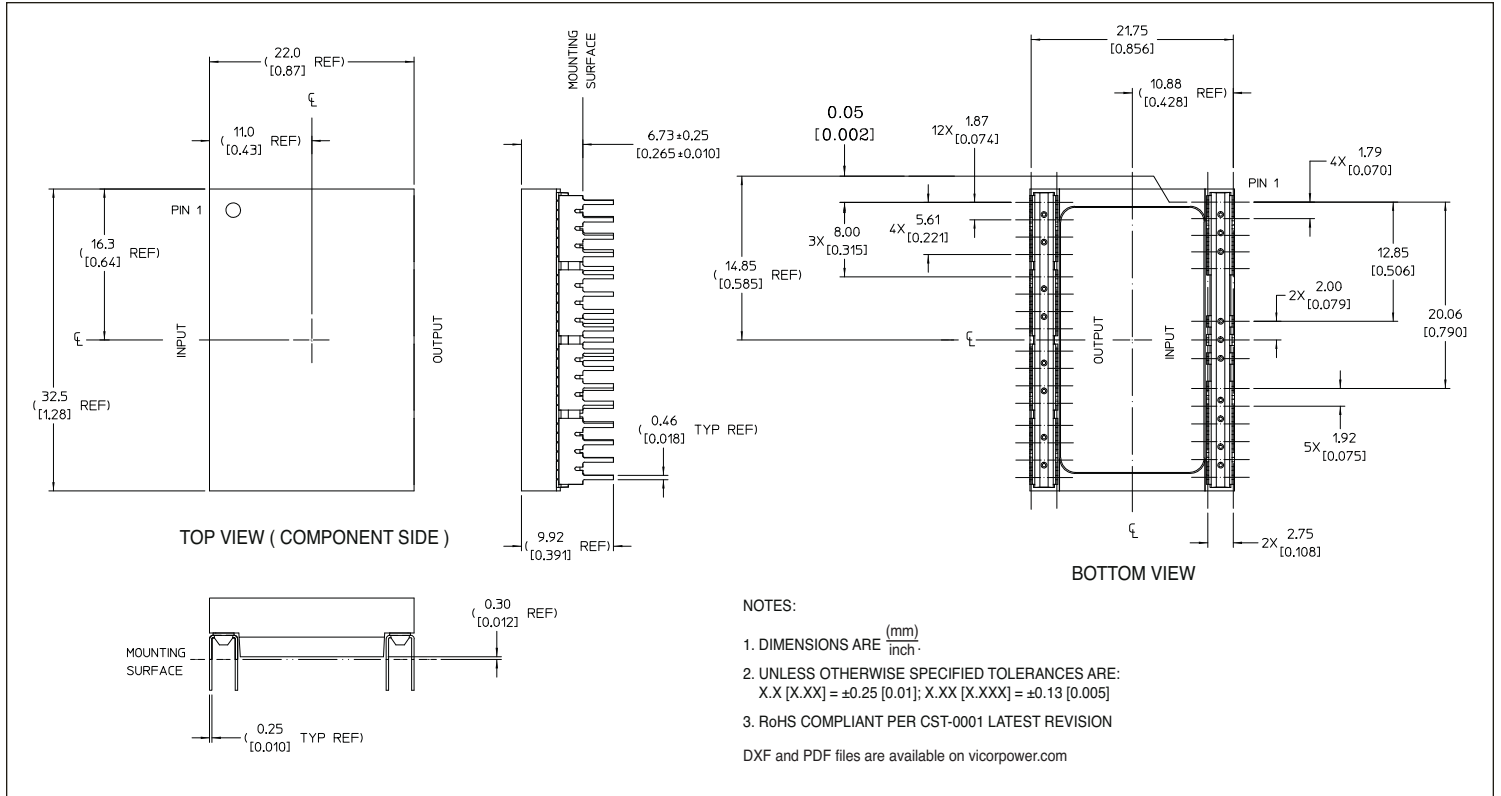

Figure 12 — VTM Through-hole mechanical outline

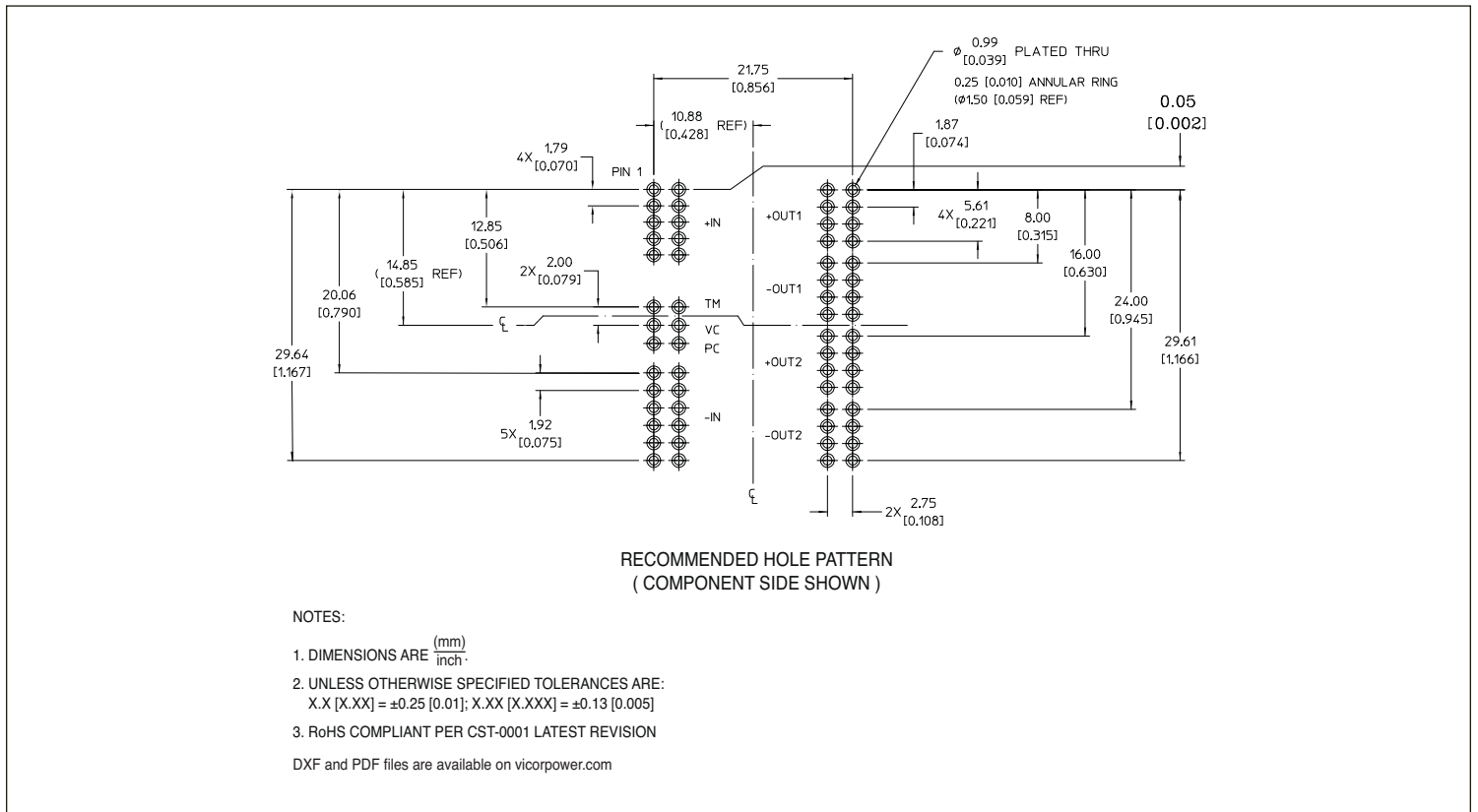
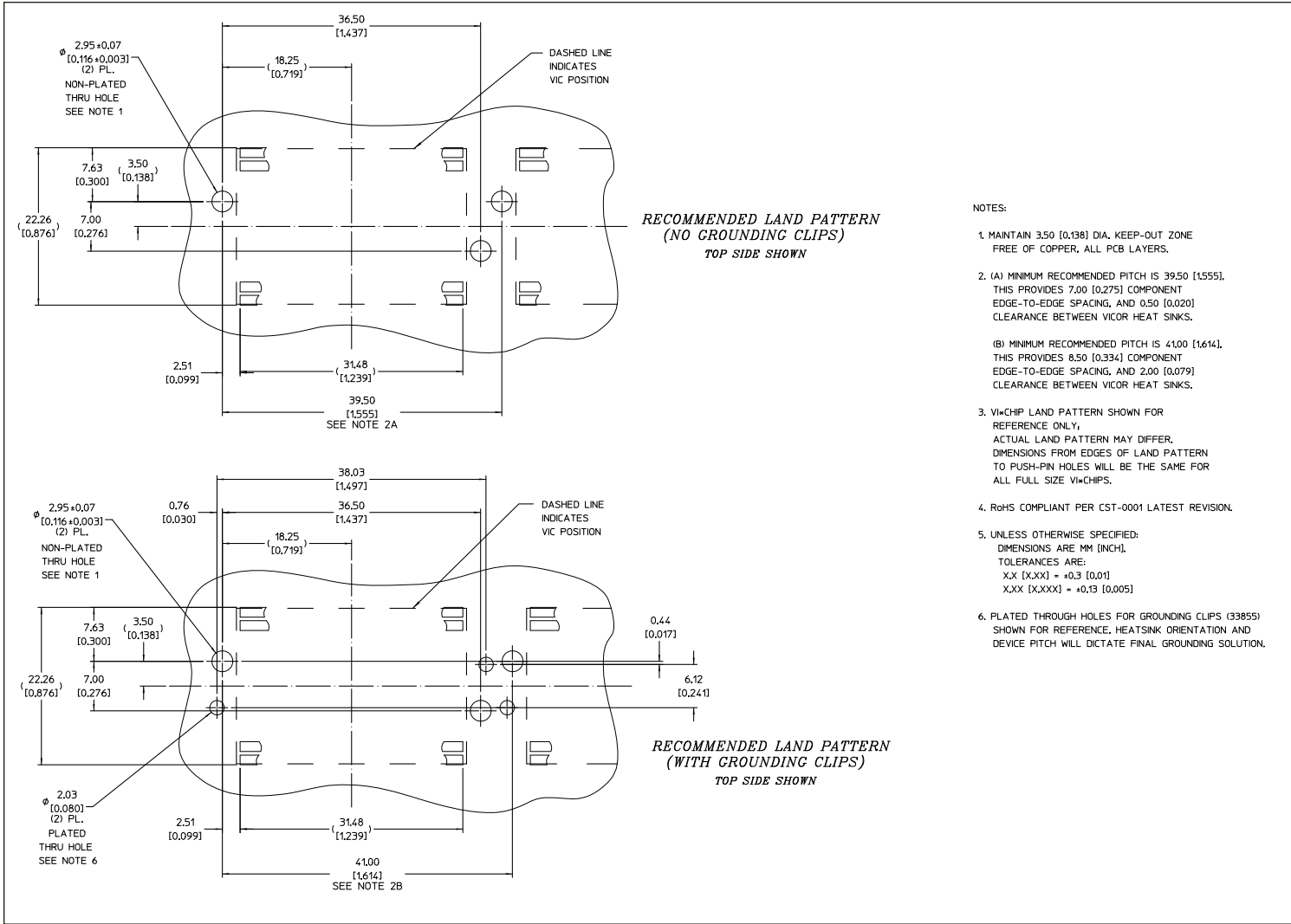

Figure 13 — VTM Through-hole PCB layout information



- NOTES:
1. MAINTAIN 3.50 [0.138] DIA. KEEP-OUT ZONE FREE OF COPPER, ALL PCB LAYERS.
  2. (A) MINIMUM RECOMMENDED PITCH IS 39.50 [1.555]. THIS PROVIDES 7.00 [0.275] COMPONENT EDGE-TO-EDGE SPACING, AND 0.50 [0.020] CLEARANCE BETWEEN VICOR HEAT SINKS.  
  
(B) MINIMUM RECOMMENDED PITCH IS 41.00 [1.614]. THIS PROVIDES 8.50 [0.334] COMPONENT EDGE-TO-EDGE SPACING, AND 2.00 [0.079] CLEARANCE BETWEEN VICOR HEAT SINKS.
  3. V•I CHIP LAND PATTERN SHOWN FOR REFERENCE ONLY, ACTUAL LAND PATTERN MAY DIFFER. DIMENSIONS FROM EDGES OF LAND PATTERN TO PUSH-PIN HOLES WILL BE THE SAME FOR ALL FULL SIZE V•I CHIPS.
  4. ROHS COMPLIANT PER CST-0001 LATEST REVISION.
  5. UNLESS OTHERWISE SPECIFIED: DIMENSIONS ARE MM [INCH]. TOLERANCES ARE:  
X.X [X.XX] = +0.3 [0.01]  
X.XX [X.XXX] = +0.13 [0.005]
  6. PLATED THROUGH HOLES FOR GROUNDING CLIPS (33855) SHOWN FOR REFERENCE. HEATSINK ORIENTATION AND DEVICE PITCH WILL DICTATE FINAL GROUNDING SOLUTION.

Figure 14 — Hole location for push pin heat sink relative to V•I Chip

## Application Note

### Parallel Operation

In applications requiring higher current or redundancy, VTM's can be operated in parallel without adding control circuitry or signal lines. To maximize current sharing accuracy, it is imperative that the source and load impedance on each VTM in a parallel array be equal. If VTM's are being fed by an upstream PRM, the VC nodes of all VTM's must be connected to the PRM VC.

To achieve matched impedances, dedicated power planes within the PC board should be used for the output and output return paths to the array of paralleled VTM's. This technique is preferable to using traces of varying size and length.

The VTM power train and control architecture allow bi-directional power transfer when the VTM is operating within its specified ranges. Bi-directional power processing improves transient response in the event of an output load dump. The VTM may operate in reverse, returning output power back to the input source. It does so efficiently.

### Thermal Considerations

V•I Chip products are multi-chip modules whose temperature distribution varies greatly for each part number as well as with the input/output conditions, thermal management and environmental conditions. Maintaining the top of the V048F240T012 case to less than 100°C will keep all junctions within the V•I Chip below 125°C for most applications. The percent of total heat dissipated through the top surface versus through the J-lead is entirely dependent on the particular mechanical and thermal environment. The heat dissipated through the top surface is typically 60%. The heat dissipated through the J-lead onto the PCB board surface is typically 40%. Use 100% top surface dissipation when designing for a conservative cooling solution. It is not recommended to use a V•I Chip for an extended period of time at full load without proper heatsinking.

### Input Impedance Recommendations

To take full advantage of the VTM's capabilities, the impedance of the source (input source plus the PC board impedance) must be low over a range from DC to 5 MHz. Input bypass capacitance may be added to improve transient performance or compensate for high source impedance. The VTM has extremely wide bandwidth so the source response to transients is usually the limiting factor in overall output response of the VTM.

Anomalies in the response of the source will appear at the output of the VTM, multiplied by its K factor of 1/2. The DC resistance of the source should be kept as low as possible to minimize voltage deviations on the input to the VTM. If the VTM is going to be operating close to the high limit of its input range, make sure input voltage deviations will not trigger the input overvoltage turn-off threshold.

### Input Fuse Recommendations

V•I Chips are not internally fused in order to provide flexibility in configuring power systems. However, input line fusing of V•I Chips must always be incorporated within the power system. A fast acting fuse is required to meet safety agency Conditions of Acceptability. The input line fuse should be placed in series with the +In port.

### Application Notes

For VTM and V•I Chip application notes on soldering, thermal management, board layout, and system design click on the link below:  
[http://www.vicorpower.com/technical\\_library/application\\_information/chips/](http://www.vicorpower.com/technical_library/application_information/chips/)

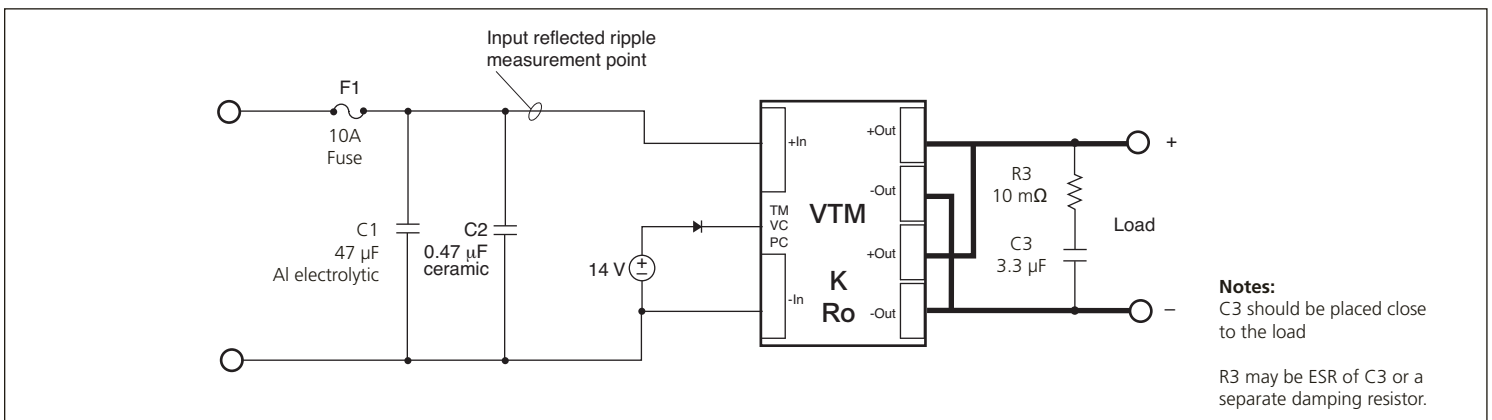
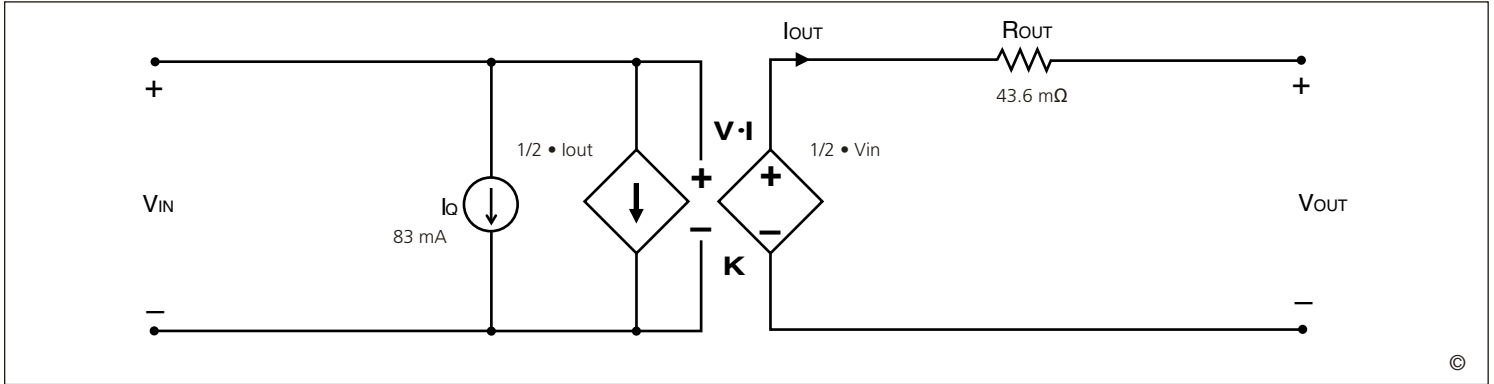

Figure 15 — VTM test circuit

### V•I Chip VTM Level 1 DC Behavioral Model for 48 V to 24 V, 12.5 A



**Figure 16** — This model characterizes the DC operation of the V•I Chip VTM, including the converter transfer function and its losses. The model enables estimates or simulations of output voltage as a function of input voltage and output load, as well as total converter power dissipation or heat generation.

### V•I Chip VTM Level 2 Transient Behavioral Model for 48 V to 24 V, 12.5 A

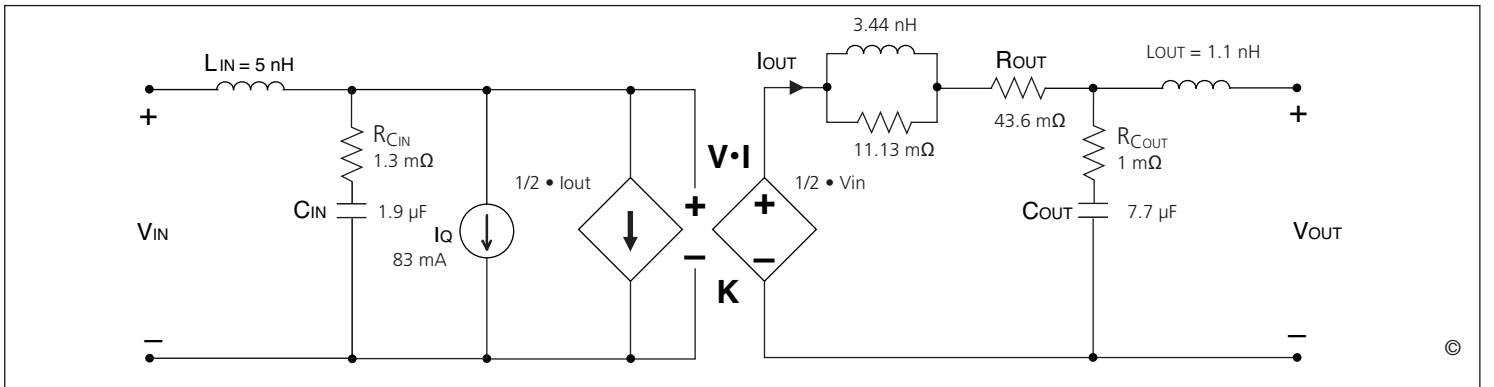

**Figure 17** — This model characterizes the AC operation of the V•I Chip VTM including response to output load or input voltage transients or steady state modulations. The model enables estimates or simulations of input and output voltages under transient conditions, including response to a stepped load with or without external filtering elements.

In figures below;

K = VTM transformation ratio  
 R<sub>O</sub> = VTM output resistance

V<sub>f</sub> = PRM output (Factorized Bus Voltage)  
 V<sub>O</sub> = VTM output  
 V<sub>L</sub> = Desired load voltage

### FPA Adaptive Loop

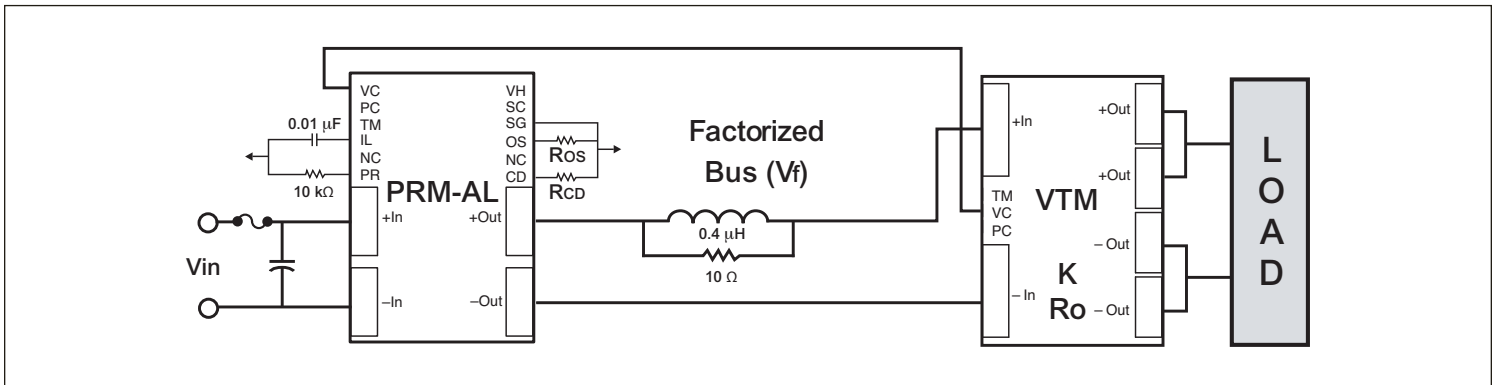

**Figure 18** — The PRM controls the factorized bus voltage, V<sub>f</sub>, in proportion to output current to compensate for the output resistance, R<sub>o</sub>, of the VTM. The VTM output voltage is typically within 1% of the desired load voltage (V<sub>L</sub>) over all line and load conditions.

## Warranty

Vicor products are guaranteed for two years from date of shipment against defects in material or workmanship when in normal use and service. This warranty does not extend to products subjected to misuse, accident, or improper application or maintenance. Vicor shall not be liable for collateral or consequential damage. This warranty is extended to the original purchaser only.

EXCEPT FOR THE FOREGOING EXPRESS WARRANTY, VICOR MAKES NO WARRANTY, EXPRESS OR IMPLIED, INCLUDING, BUT NOT LIMITED TO, THE WARRANTY OF MERCHANTABILITY OR FITNESS FOR A PARTICULAR PURPOSE.

Vicor will repair or replace defective products in accordance with its own best judgement. For service under this warranty, the buyer must contact Vicor to obtain a Return Material Authorization (RMA) number and shipping instructions. Products returned without prior authorization will be returned to the buyer. The buyer will pay all charges incurred in returning the product to the factory. Vicor will pay all reshipment charges if the product was defective within the terms of this warranty.

Information published by Vicor has been carefully checked and is believed to be accurate; however, no responsibility is assumed for inaccuracies. Vicor reserves the right to make changes to any products without further notice to improve reliability, function, or design. Vicor does not assume any liability arising out of the application or use of any product or circuit; neither does it convey any license under its patent rights nor the rights of others. Vicor general policy does not recommend the use of its components in life support applications wherein a failure or malfunction may directly threaten life or injury. Per Vicor Terms and Conditions of Sale, the user of Vicor components in life support applications assumes all risks of such use and indemnifies Vicor against all damages.

## **Vicor's comprehensive line of power solutions includes high density AC-DC and DC-DC modules and accessory components, fully configurable AC-DC and DC-DC power supplies, and complete custom power systems.**

Information furnished by Vicor is believed to be accurate and reliable. However, no responsibility is assumed by Vicor for its use. Vicor components are not designed to be used in applications, such as life support systems, wherein a failure or malfunction could result in injury or death. All sales are subject to Vicor's Terms and Conditions of Sale, which are available upon request.

## **Specifications are subject to change without notice.**

## Intellectual Property Notice

Vicor and its subsidiaries own Intellectual Property (including issued U.S. and Foreign Patents and pending patent applications) relating to the products described in this data sheet. Interested parties should contact Vicor's Intellectual Property Department.

The products described on this data sheet are protected by the following U.S. Patents Numbers: 5,945,130; 6,403,009; 6,710,257; 6,911,848; 6,930,893; 6,934,166; 6,940,013; 6,969,909; 7,038,917; 7,145,186; 7,166,898; 7,187,263; 7,202,646; 7,361,844; D496,906; D505,114; D506,438; D509,472; and for use under 6,975,098 and 6,984,965

### **Vicor Corporation**

25 Frontage Road  
Andover, MA, USA 01810  
Tel: 800-735-6200  
Fax: 978-475-6715

### **email**

Customer Service: [custserv@vicorpower.com](mailto:custserv@vicorpower.com)  
Technical Support: [apps@vicorpower.com](mailto:apps@vicorpower.com)