

7 Amp Active EMI Filter for 48 V DC Bus

Description

The QPI-4 active EMI filter attenuates conducted common-mode (CM) and differential-mode (DM) noise over the CISPR22 frequency range of 150 kHz to 30 MHz. The product is designed for use on a 48 Vdc bus (36-76 Vdc). The QPI-4's 7 A rating supports multiple DC-DC converter loads up to a PCB temperature of 60°C. At a 100°C PCB temperature the QPI-4 supports 6 A loads. Designed for the telecom and ITE bus range, the QPI-4 supports the PICMG® 3.0 specification for filtering system boards to the EN55022 Class B limits.

In comparison to passive solutions, the use of active filtering reduces the volume of the common-mode choke, providing a low profile, surface mount device. Smaller size saves valuable board real estate and the reduced height enhances airflow in blade applications.

The QPI-4 is available in a 1.0" x 1.0" x 0.2" SiP (System in Package) with LGA mounting. QPI-4-EVAL1 kits are available for testing the QPI-4. The evaluation board has a mounted QPI-4 with screw terminals for quick in-circuit testing.

Check picorpower.com for the QPI-4-EVAL1 evaluation board and the QPI-AN1 Application Note.

Features

- >40 dB CM attenuation at 250 kHz
- >70 dB DM attenuation at 250 kHz
- 80 Vdc (max input)
- 7 Amp rating
- 100 Vdc surge 100 ms
- 1,500 Vdc Hi-pot hold off to Shield Plane
- 1.0" x 1.0" x 0.2" SiP (System-in-Package)
- SMT Land Grid Array (LGA)
- -40° to +100°C PCB temperature (See Fig. 5)
- Active filtering reduces volume and height
- Efficiency >99% at full load
- Connect in series for higher attenuation
- TÜV approved

Applications

- ATCA blades
- Telecom base stations
- IBA & distributed power

Typical Application

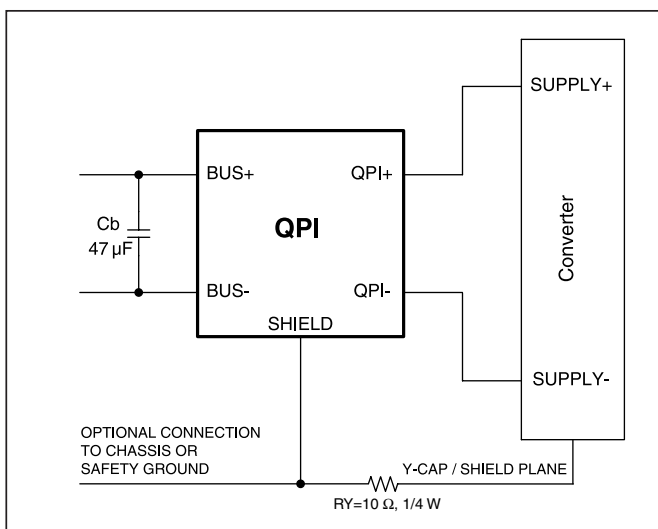

Figure 1 - QPI-4 circuit on input bus.

QPI Performance

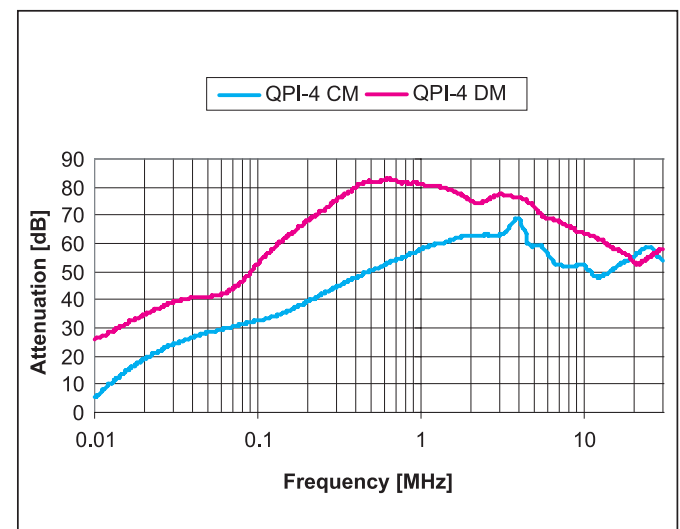

Figure 2 - Attenuation curves showing common-mode and differential-mode attenuation.

Absolute Maximum Ratings – Exceeding these parameters may result in permanent damage to the product.

Pins	Parameter	Notes	Min	Max	Units
BUS+ to BUS-	Input voltage	Continuous	-80	80	Vdc
BUS+ to BUS-	Input voltage	100ms transient	-100	100	Vdc
BUS+/BUS- to Shield Plane	BUS inputs to Shield Hipot	Per test std.		+/-1500	Vdc
QPI+ to QPI-	Input to output current	Continuous @ 25°C		7	Adc
Package	Power dissipation	VBUS = 48 V, IBUS = 7 Adc, 25°C		2.0	W
Package	Operating temperature	PCB to QPI Interface	-40	100	°C
Package	Thermal resistance	Free air		50	°C/W
Package	Junction temperature	Internal @ P _{dmax} and 15°C/W		130	°C
Package	Thermal resistance	PCB layout (see Figs. 9 & 10) ¹		15	°C/W
Package	Storage temperature		-40	125	°C
Package	Re-flow temperature	20 second exposure @		212	°C
All Pins	ESD	HBM		+/-2	kV

Note 1 - Refer to Figures 9 & 10 for PCB layout guidelines to achieve this thermal resistance when re-flowed onto the PCB.

Electrical Characteristics – Parameter limits apply over the operating temp. range unless otherwise noted.

Parameter	Notes	Min	Typ	Max	Units
BUS+ to BUS- input range	Measured at 7 A ²	30		80	Vdc
BUS+ to QPI+ voltage drop	Measured at 7 A ²		100		mVdc
BUS- to QPI- voltage drop	Measured at 7 A ²		20		mVdc
Common-mode insertion loss	VBUS = 48 V frequency = 500 kHz		42		dB
Differential-mode insertion loss	VBUS = 48 V frequency = 500 kHz		72		dB
Input bias current at 80 Volts	Input current from BUS+ to BUS-		8		mA

Note 2 - Refer to Figure 5 for current derating curve.

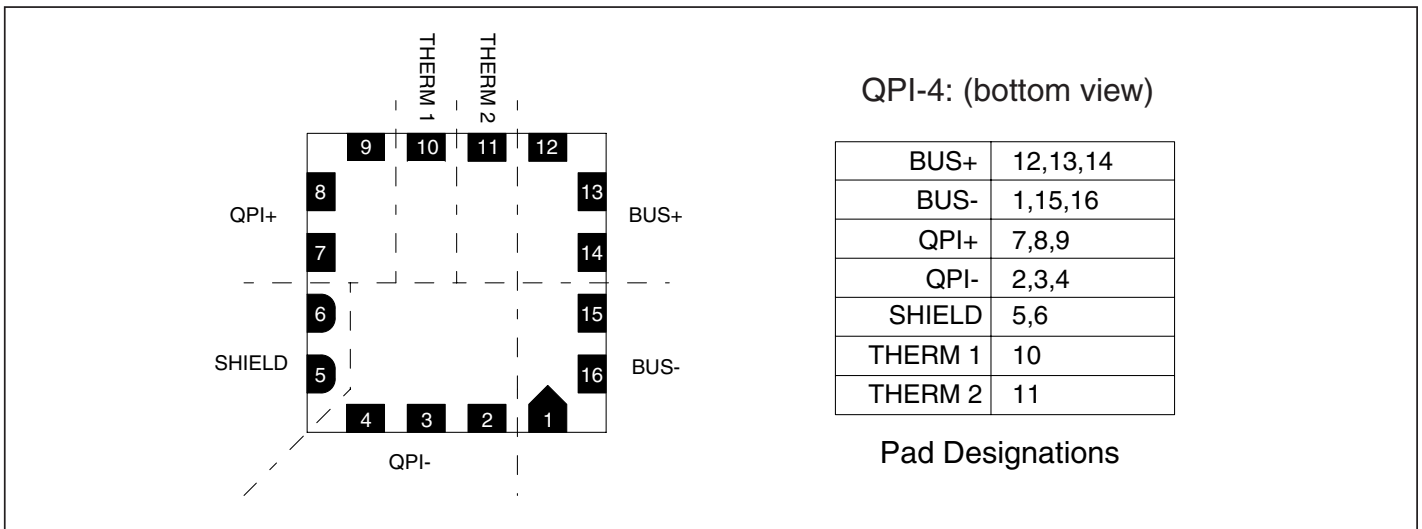

Pad Description

BUS-	Negative bus potential	THERM1 THERM2	Internal connection must be electrically floating but maximize copper landing for heat sinking.
BUS+	Positive bus voltage		
QPI-	Negative input to the converter	Shield	The shield connects to the converter shield and Y capacitor common point through RY.
QPI+	Positive input to the converter		

Applications Information

The QPI-4 is an active EMI filter providing conducted common-mode and differential-mode attenuation from 150 kHz to 30 MHz. The QPI-4 attenuates noise at all frequencies covered by EN55022. Designers should be aware that to select and qualify an EMI filter they must test the filter in their equipment under the set up and conditions specified in the EMI standards that they are trying to meet.

Filter performance is highly dependent on several factors and cannot be derived from the attenuation curves shown in *Figure 2* alone. Performance is a complex function of filter element impedances and noise source impedances, which vary in magnitude and phase over the frequency spectrum. Measurements should be made in consultation with in-house compliance testing or an independent EMI test facility.

Test Example

Figures 3 and 4 show the before and after plots of a DC-DC converter noise profile to demonstrate the performance of the QPI-4. The plots were taken using the standard measurement technique and set up defined in CISPR22. The results show the total noise spectrum for a standard DC-DC converter under load compared to the EN55022 Class B Quasi-peak detection limit.

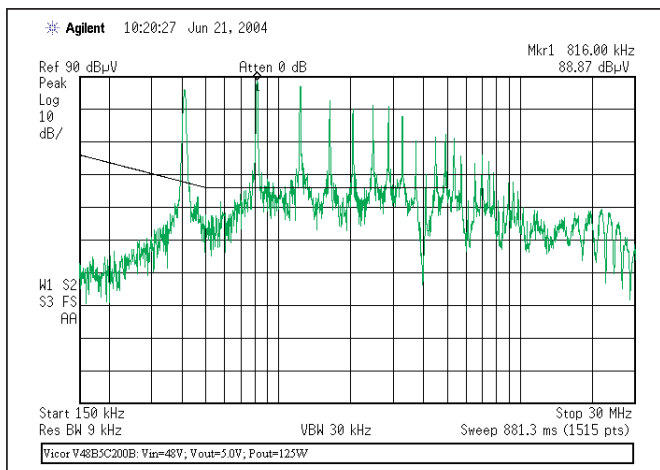

Figure 3 – Conducted EMI profile of a DC-DC Converter without filter.

The resulting plot in *Figure 4* shows the QPI-4 is effective in reducing the total conducted noise spectrum measured pre-filter to well below the EN55022 Class B Quasi-peak detection limit.

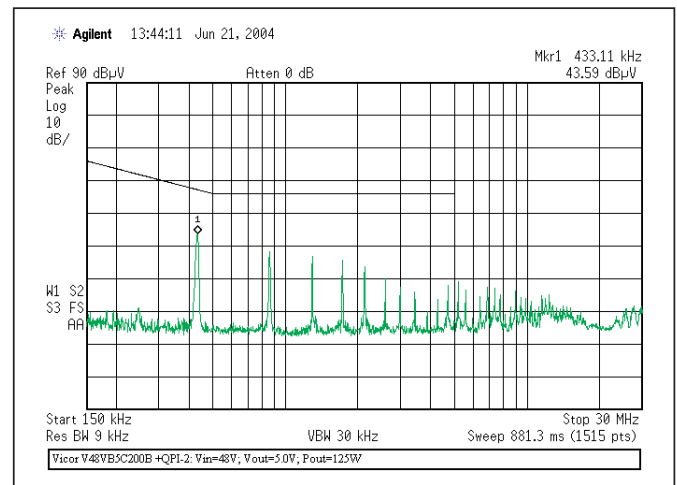

Figure 4 – Conducted EMI profile of a DC-DC Converter with QPI-4.

Layout and Circuit

Application of the QPI-4 requires PCB layout practices similar to those used with passive EMI filters. The circuit in *Figure 6* and the PCB layout in *Figures 9 & 10* should be used as a design guide to ensure successful application of the QPI-4. Refer to the application note QPI- AN1 for additional PCB layout recommendations.

Note: For optimum performance of the QPI-4 it is critical to connect the QPI-4 Shield Plane (pins 5 & 6) to the converter EMI Shield Plane (common point of C1-C4"Y" capacitors) thru RY as shown in *Figure 6*. If the safety earth-ground connection (chassis or case) is connected in the power conversion section of the PCB it should be at the input bus of the QPI-4 Shield Plane, shown as the optional connection in *Figure 6*. Connecting the converter EMI shield plane directly to chassis ground may degrade the QPI-4 attenuation performance. The typical value for RY is 3.9 Ohms. The recommended part is a 5% tolerance SMT1206 or similarly rated 0.25 W through-hole resistor.

QPIs will filter multiple DC-DC converters up to the maximum current rating. The schematic in *Figure 7* shows the required circuit for multiple DC-DC converters. The Shield Plane should be added under each converter as a common EMI Shield. Note that only a single RY is required in a multiple converter configuration.

If higher attenuation is required, QPIs can be connected in series. *Figure 8* shows the proper schematic for QPIs in series. Note that only one RY is required in this configuration.

The QPI can also be used to filter embedded or “down” converters made up of discrete components. Where ever possible a Shield Plane and Y-capacitor decoupling should be included in the embedded converter design. Follow the circuit and layout recommendations for a brick converter shown in *Figures 7, 9 & 10*.

Thermal Considerations

The current derating curve shown in *Figure 5* should be used when the PCB temperature in close proximity of the QPI-4 exceeds 60°C. For example, the QPI-4 will support up to 6.5 A of current or 312 W from a 48 Vdc bus at an 80°C interface temperature. Temperature should be measured at the PCB interface to the QPI-4 on the Bus +/- pads or the QPI+/- pads. Refer to *Figures 9, 10 & 12* for PCB layout recommendation.

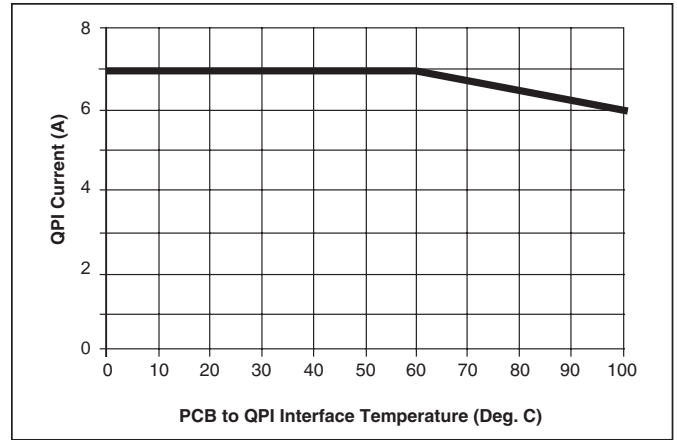

Figure 5 – QPI-4 current derating curve.

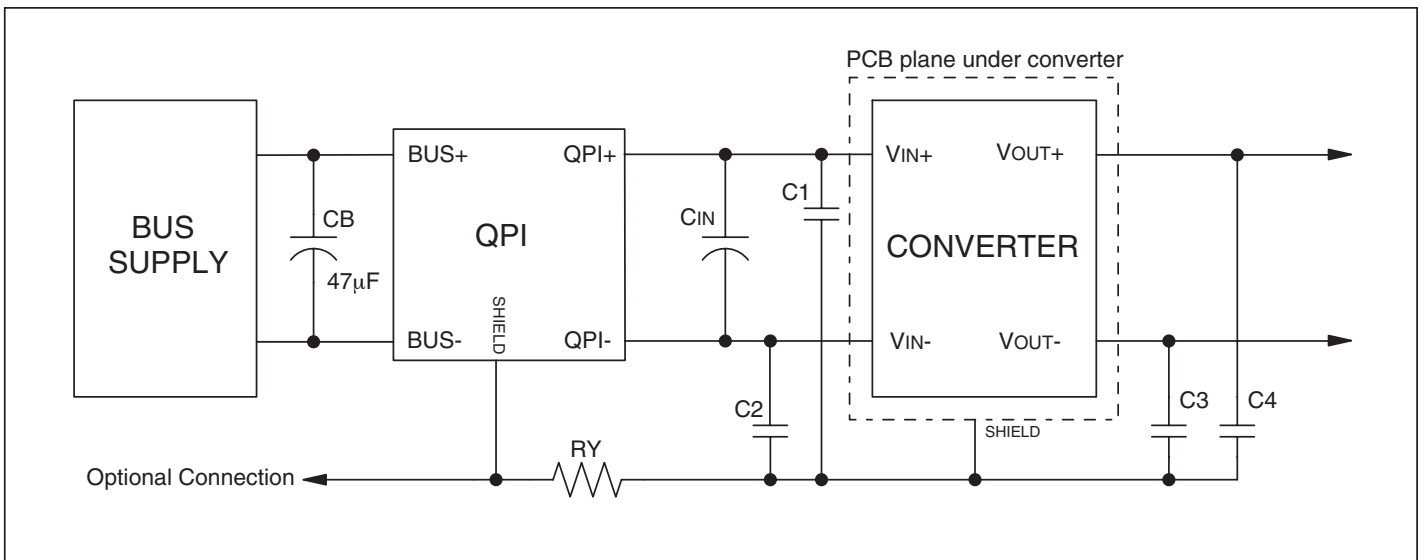

Figure 6 – Recommended schematic for QPI. Values of C_{IN} and C1-C4 should be the values recommended by the converter manufacturer. If the manufacturer does not specify a value for the Y-capacitors use 4.7nF. $R_y=10\Omega$, 1/4 W.

Ordering Information

Part Number	Description
QPI-4L	QPI-4 Land Grid Array

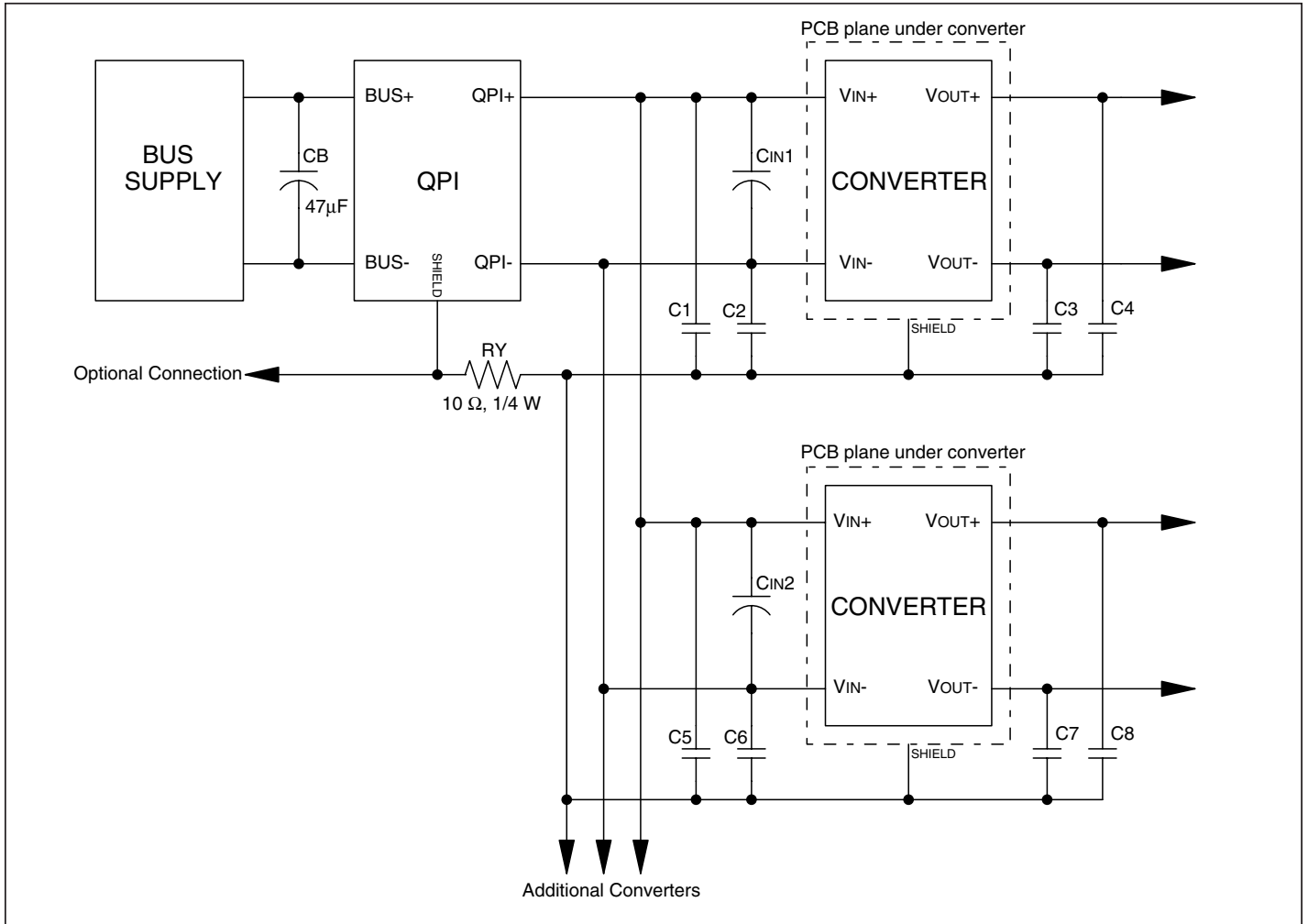

Figure 7 – Schematic for supporting multiple DC-DC converters. Note only a single RY is required. Use values recommended by converter manufacturer for CIN and Y-capacitors C1-C8.

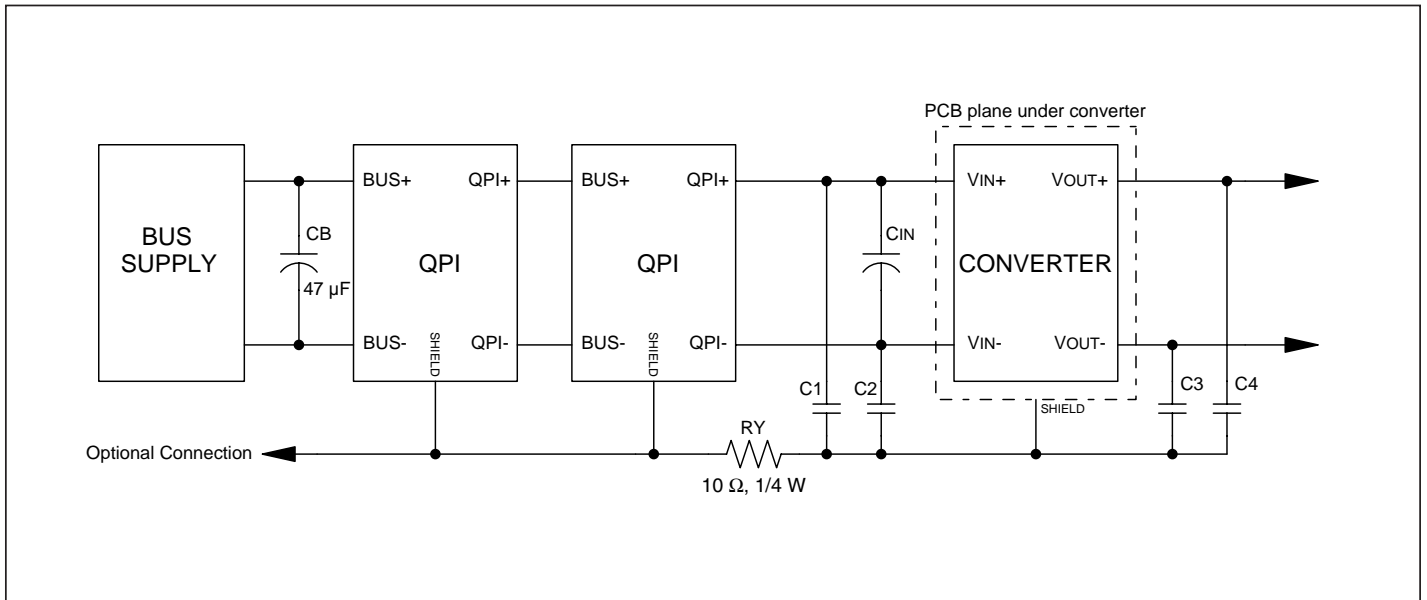
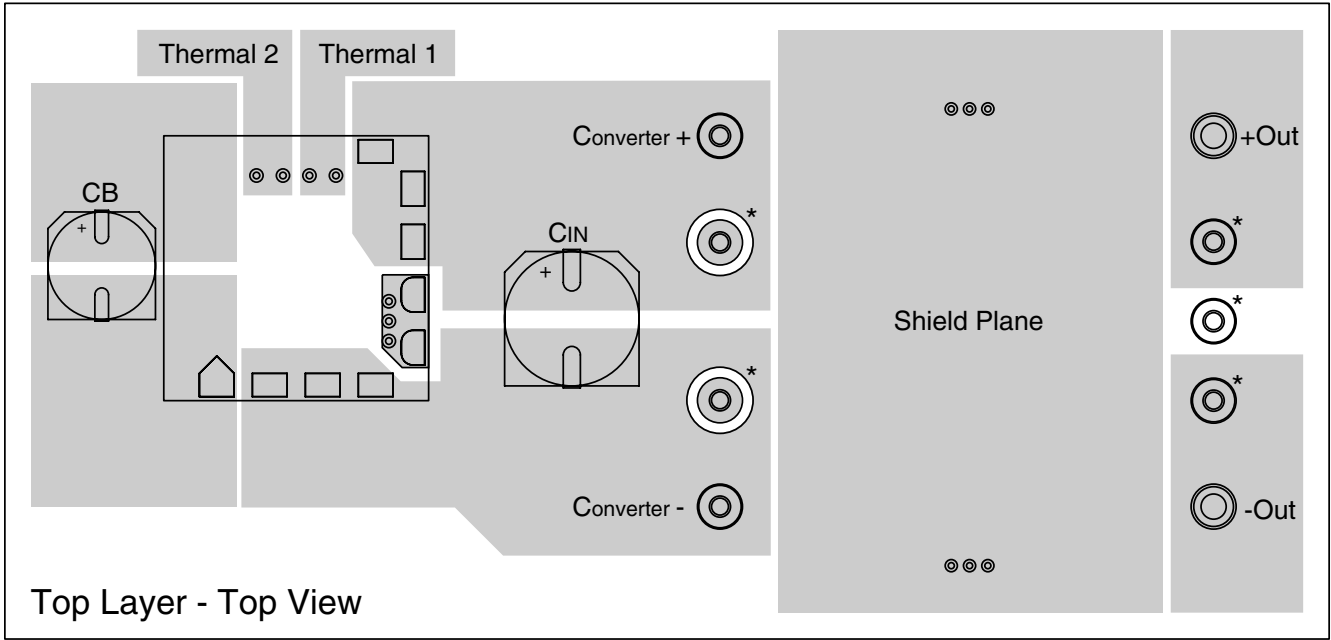
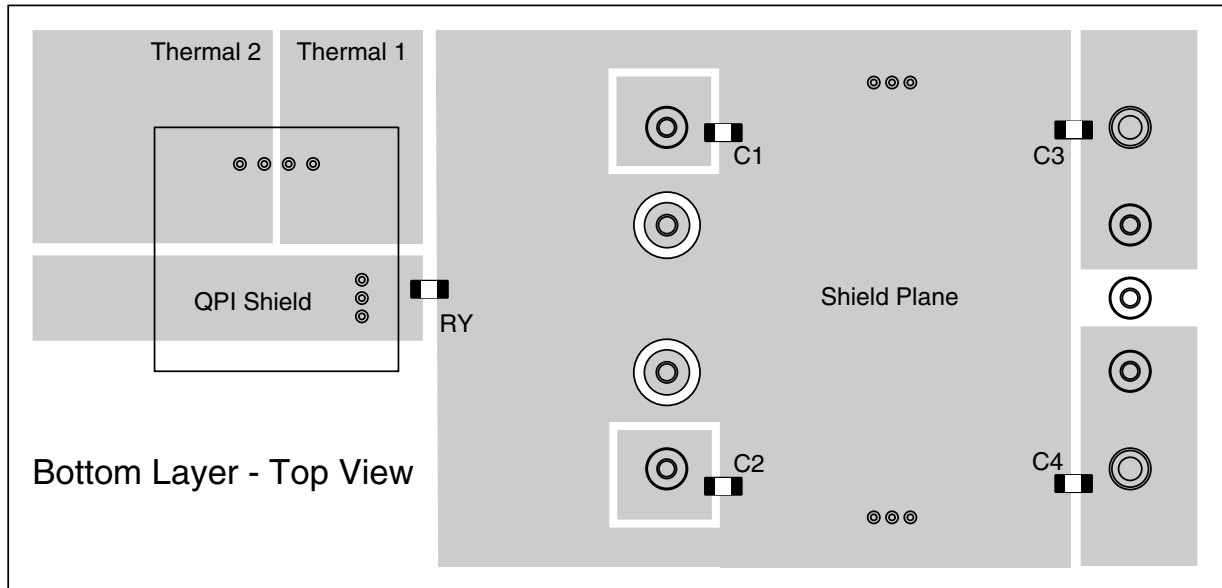

Figure 8 – Series connection of QPI for higher attenuation.



Top Layer - Top View

Figure 9 – Recommended layout for top layer of PCB. Pattern shows optional pins (*) dependent on converter used in design. (Actual size with half brick footprint)



Bottom Layer - Top View

Figure 10 – Recommended layout for bottom layer of PCB. Note location of RY.

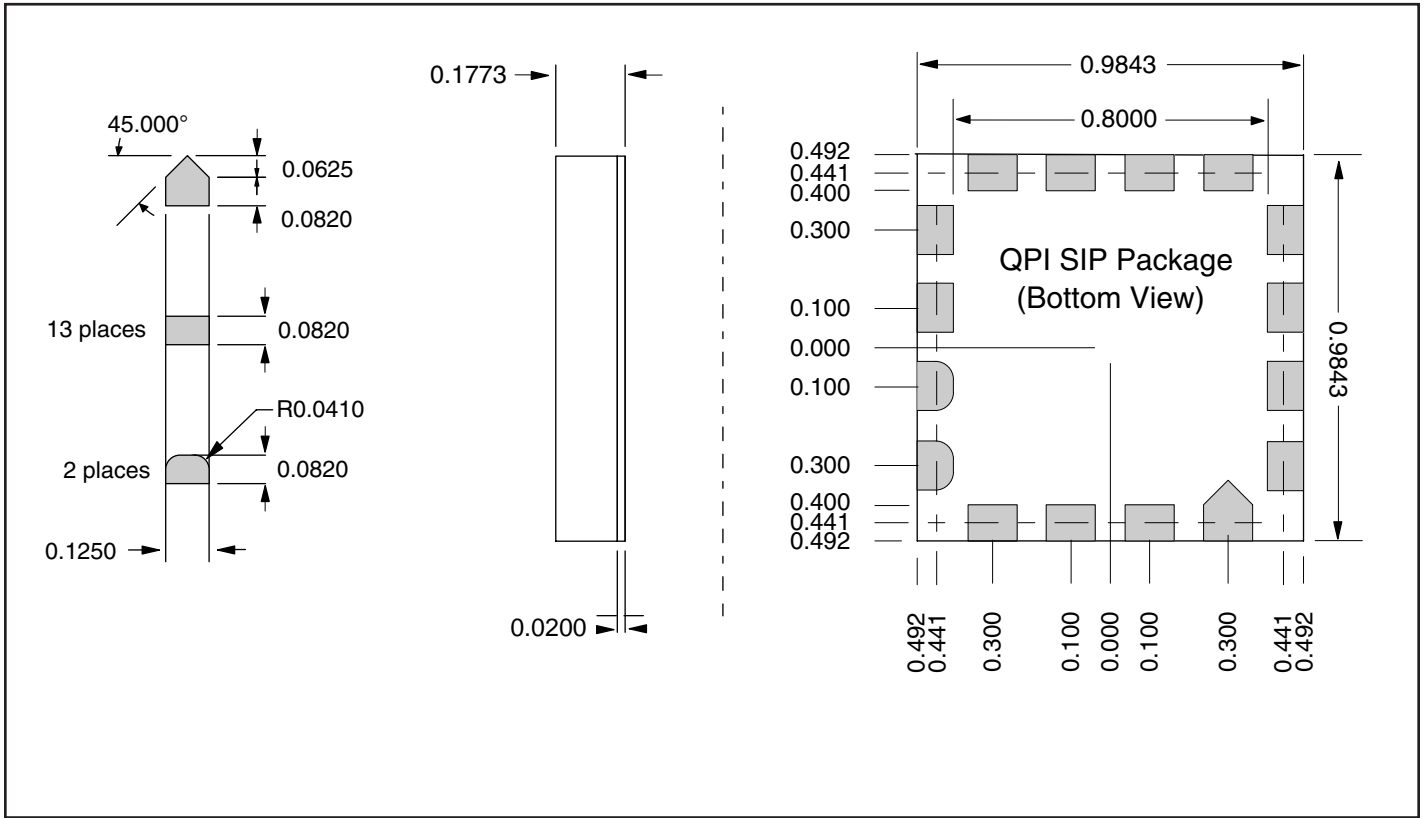

Figure 11 – QPI package dimensions and pad locations.

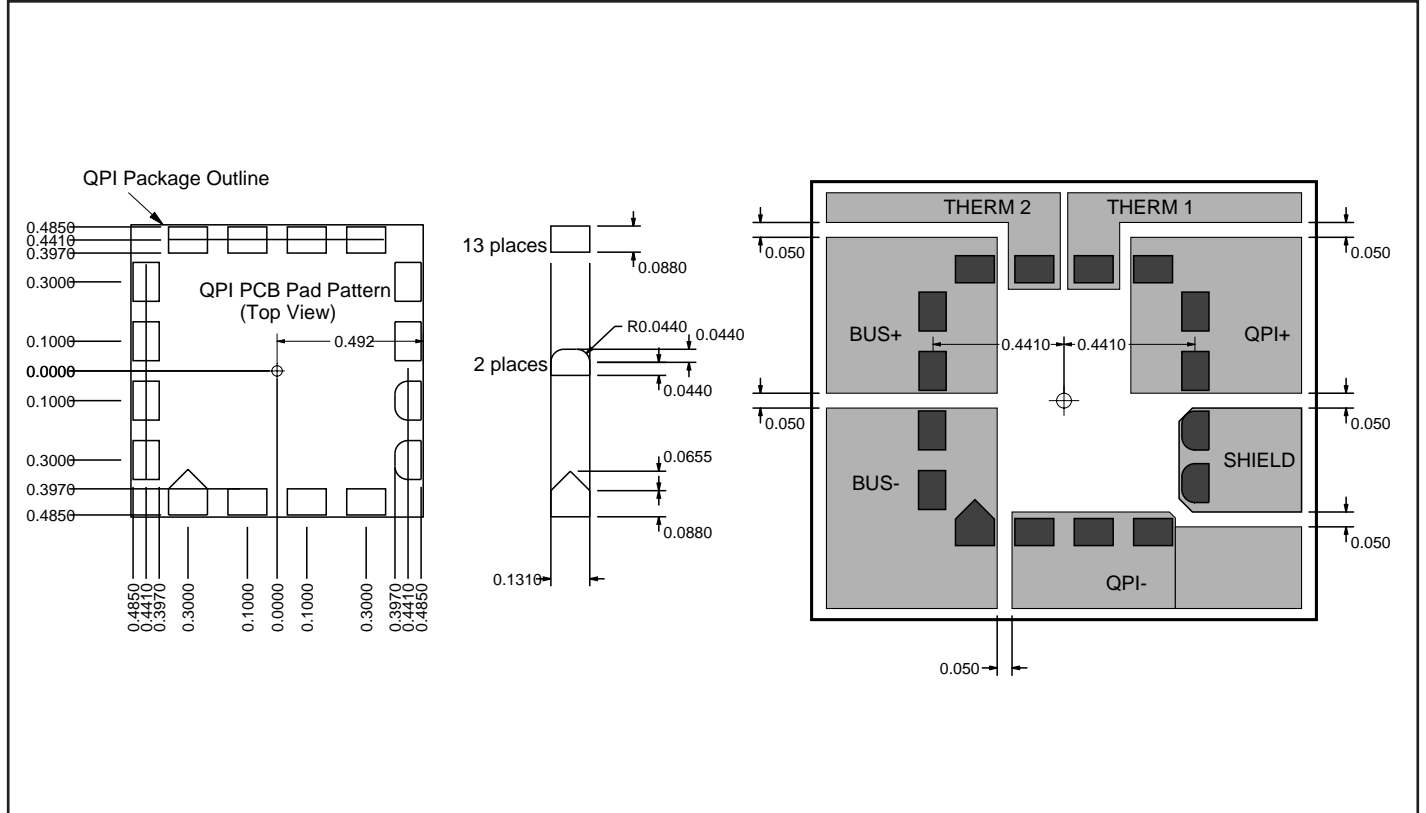

Figure 12 –Recommended PCB layout pattern. Use 1.3mm clearance around shield pads 5 & 6 to adjacent lands. See Figures 9 & 10 for recommended connection layouts.

Vicor's comprehensive line of power solutions includes high-density AC-DC & DC-DC modules and accessory components, fully configurable AC-DC & DC-DC power supplies, and complete custom power systems.

Information furnished by Vicor is believed to be accurate and reliable. However, no responsibility is assumed by Vicor for its use. No license is granted by implication or otherwise under any patent or patent rights of Vicor. Vicor components are not designed to be used in applications, such as life support systems, wherein a failure or malfunction could result in injury or death. All sales are subject to Vicor's Terms and Conditions of Sale, which are available upon request.

Specifications are subject to change without notice.



Vicor Corporation
25 Frontage Road, Andover, MA, USA 01810
Tel: 800-735-6200 Fax: 978-475-6715

Email
Vicor Express: vicorexp@vicor.com
Technical Support: apps@vicor.com