

## Features

- 352 V to 11 V VI BRICK™ BCM Array
- 300 Watt (450 Watt for 1 ms)
- Vertical mount package reduces footprint
- Integrated heat sink simplifies thermal management
- ZVS / ZCS isolated sine amplitude converter
- Typical efficiency 95%
- <1 μs transient response
- >3.5 million hours MTBF
- Internal fuse and filter
- No output filtering required

Vin = 330 – 365 V  
Vout = 10.3 – 11.4 V  
Iout = 27.3 A  
K = 1/32  
Rout = 15 mΩ max

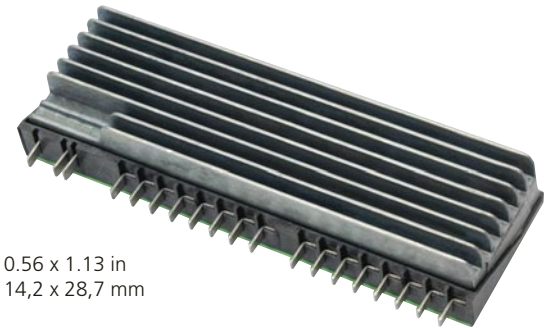

Size:  
3.54 x 0.56 x 1.13 in  
89,9 x 14,2 x 28,7 mm

## Product Description

The BC352R110T030VM-00 contains two high efficiency, narrow input range Sine Amplitude Converter (SAC) converters operating from a 330 to 365 Vdc primary bus to deliver an isolated low voltage secondary. The module provides an isolated 10.3 -11.4 V distribution bus and is packaged in a thermally efficient VI BRICK BCM Array package. Due to the fast response time and low noise, the need for limited life aluminum electrolytic or tantalum capacitors at the input of POL converters is reduced—or eliminated—resulting in savings of board area, materials and total system cost.

The BC352R110T030VM-00 achieves a power density of 134 W/in<sup>3</sup> in a VI BRICK BCM Array package utilizing an integrated heat sink. Owing to its high conversion efficiency and safe operating temperature range, the VI BRICK BCM Array does not require additional heat sinking or high airflow velocities. Low junction-to-heat sink thermal impedance assures low junction temperatures and long life in the harshest environments.

## Absolute Maximum Ratings

Parameter	Values	Unit	Notes
+In to -In	-1.0 to 400	Vdc	
+In to -In	500	Vdc	For 100 ms
PC to -In	-0.3 to 7.0	Vdc	
+Out to -Out	-0.5 to 16	Vdc	
Isolation voltage	4,242	Vdc	Input to Output
Output current	30.4	A	Continuous
Peak output current	41	A	For 1 ms
Output power	300	W	Continuous
Peak output power	450	W	For 1 ms
Operating junction temperature <sup>(1)</sup>	-40 to 125	°C	T-Grade
Storage temperature	-40 to 125	°C	T-Grade

### Note:

- (1) The referenced junction is defined as the semiconductor having the highest temperature. This temperature is monitored by a shutdown comparator.

## SPECIFICATIONS

### Input Specifications *(Conditions are at 352 V<sub>in</sub>, full load, and 25°C ambient unless otherwise specified)*

Parameter	Min	Typ	Max	Unit	Note
Input voltage range	330	352	365	Vdc	
Input dV/dt			1	V/μs	
Input undervoltage turn-on			325	Vdc	
Input undervoltage turn-off	275			Vdc	
Input overvoltage turn-on	366			Vdc	
Input overvoltage turn-off			399	Vdc	
Input quiescent current		1.2		mA	PC low
Input current			0.9	Adc	
No load power dissipation		4.3	7	W	
Internal input capacitance		0.2		μF	
Internal input inductance		5.0		μH	

### Output Specifications *(Conditions are at 352 V<sub>in</sub>, full load, and 25°C ambient unless otherwise specified)*

Parameter	Min	Typ	Max	Unit	Note
Output voltage	10.3		11.4	Vdc	No load; 330 – 365 V <sub>IN</sub>
	9.91		11	Vdc	Full load; 330 – 365 V <sub>IN</sub>
Output power	0		300	W	330 - 365 V <sub>IN</sub> ; 100°C heat sink max. temp.
Rated DC current	0		30.4	Adc	P <sub>OUT</sub> ≤ 300 W
Peak repetitive power			450	W	Max pulse width 1ms, max duty cycle 10%, baseline power 50%
Current share accuracy		5	10	%	
Efficiency					
Half load	93.5	95.8		%	
Full load	94.3	95.5		%	
Internal output inductance		1.1		nH	
Internal output capacitance		31		μF	Effective value
Load capacitance			1,200	μF	
Output overvoltage setpoint	11.4			Vdc	
Output ripple voltage					
No external bypass		200	400	mV p-p	
Short circuit protection set point	38			Adc	Module will shut down
Average short circuit current		0.18		A	
Effective switching frequency	3.3	3.4	3.5	MHz	Fixed, 1.7 MHz per phase per each BCM
Line regulation					
K	0.0309	1/32	0.0316		V <sub>OUT</sub> = K•V <sub>IN</sub> at no load
Load regulation					
R <sub>OUT</sub>		12.2	15	mΩ	
Output overshoot					
Input turn-on		50		mV	No output filter
PC enable		50		mV	No output filter
Output turn-on delay					
From application of power		750		ms	No output filter
From release of PC pin		160		ms	No output filter

## SPECIFICATIONS (CONT.)

General					
Parameter	Min	Typ	Max	Unit	Note
MTBF		3.5		Mhrs	25°C, GB
Isolation specifications					
Voltage	4,242			Vdc	Input to Output
Capacitance		500		pF	Input to Output
Resistance	10			MΩ	Input to Output
Agency approvals					
		cTÜVus			Safety agency approvals pending
		CE Mark			Low Voltage Directive
Mechanical					
Weight		3.2/92		oz/g	See Mechanical Drawings
Dimensions					
Length		3.54/89,9	3.55/90,1	in/mm	
Width		0.56/14,2	0.57/14,6	in/mm	
Height		1.13/28,7	1.18/30,0	in/mm	
Thermal					
Over temperature shutdown	125	130	135	°C	Junction temperature
Operating temperature - heatsink			100	°C	See thermal curve, Figure 1
Junction-to-heatsink thermal impedance ( $R_{\theta JC}$ )		0.50	0.65	°C/W	Heatsink temperature measured in location shown in Figure 2
Heatsink to ambient thermal impedance ( $R_{\theta HA}$ ) free air			6.50		<a href="http://www.vicorpower.com/technical_library/calculators/calc_t~1.xls">http://www.vicorpower.com/technical_library/calculators/calc_t~1.xls</a>

Auxiliary Pins (Conditions are at 352 Vin, full load, and 25°C ambient unless otherwise specified)					
Parameter	Min	Typ	Max	Unit	Note
Enable / Disable (CNTRL)					
DC voltage	4.8	5.0	5.2	Vdc	
Module disable voltage	2.4	2.5		Vdc	
Module enable voltage		2.5	2.6	Vdc	
Current limit	2.4	2.5	2.9	mA	Source only
Enable delay time		160		ms	
Disable delay time		20		µs	Time from PC low to output low

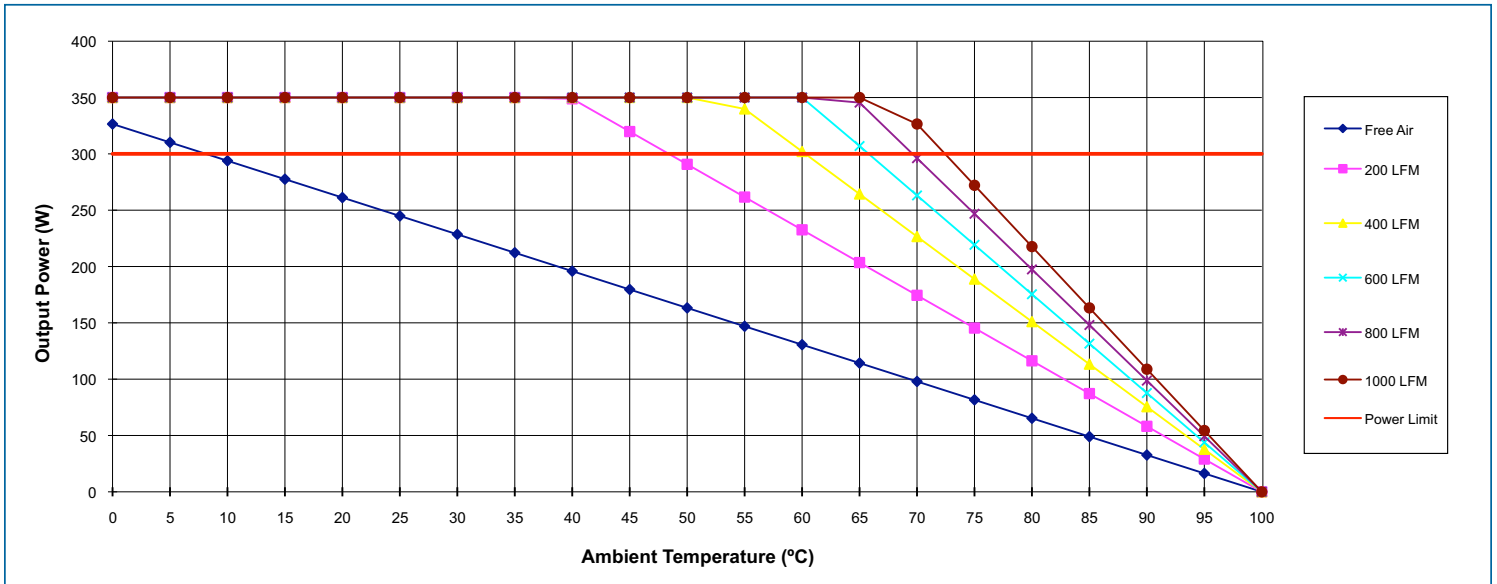

**Figure 1** – Typical thermal curve – verify all thermal management systems experimentally.

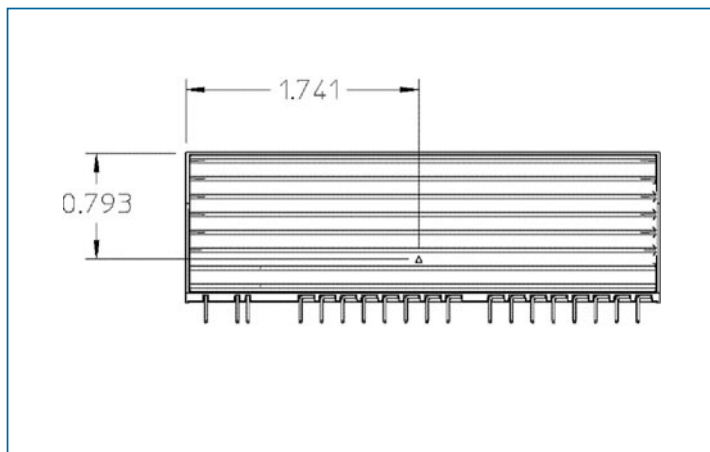

**Figure 2** — Temp measurement location

## +In / -In – DC Voltage Input Ports

The BCM Array input voltage range should not be exceeded. An internal under / over voltage lockout-function prevents operation outside of the normal operating input range. The module turns on within an input voltage window bounded by the “Input under-voltage turn-on” and “Input over-voltage turn-off” levels, as specified. The module may be protected against accidental application of a reverse input voltage by the addition of a rectifier in series with the positive input, or a reverse rectifier in shunt with the positive input located on the load side of the input fuse.

## CNTRL – Enable / Disable

The Enable / Disable signal is a multifunction node that provides the following functions:

**Enable / Disable** – If CNTRL is left floating, the module output is enabled. Once this port is pulled lower than 2.4 Vdc with respect to –In, the output is disabled. This action can be realized by employing a relay, opto-coupler, or open collector transistor. This signal should not be toggled at a rate higher than 1 Hz. CNTRL should also not be driven by or pulled up to an external voltage source.

**Primary Auxiliary Supply** – CNTRL can source up to 2.4 mA at 5.0 Vdc. CNTRL should never be used to sink current.

**Alarm** – The module contains circuitry that monitors output overload, input over voltage or under voltage, and internal junction temperatures. In response to an abnormal condition in any of the monitored parameters, CNTRL will toggle.

## +Out / -Out – DC Voltage Output Ports

Multiple pins are provided for the +Out and –Out connections. They must be connected in parallel with low interconnect resistance. Note that –Out 1B and +Out 2B shown in Figure 3 and 4 are not connected for this model.

The low output impedance of the module reduces or eliminates the need for limited life aluminum electrolytic or tantalum capacitors at the input of POL converters.

Total load capacitance at the output of the device should not exceed the specified maximum. Owing to the wide bandwidth and low output impedance of the BCM Array, low frequency bypass capacitance and significant energy storage may be more densely and efficiently provided by adding capacitance at the input.

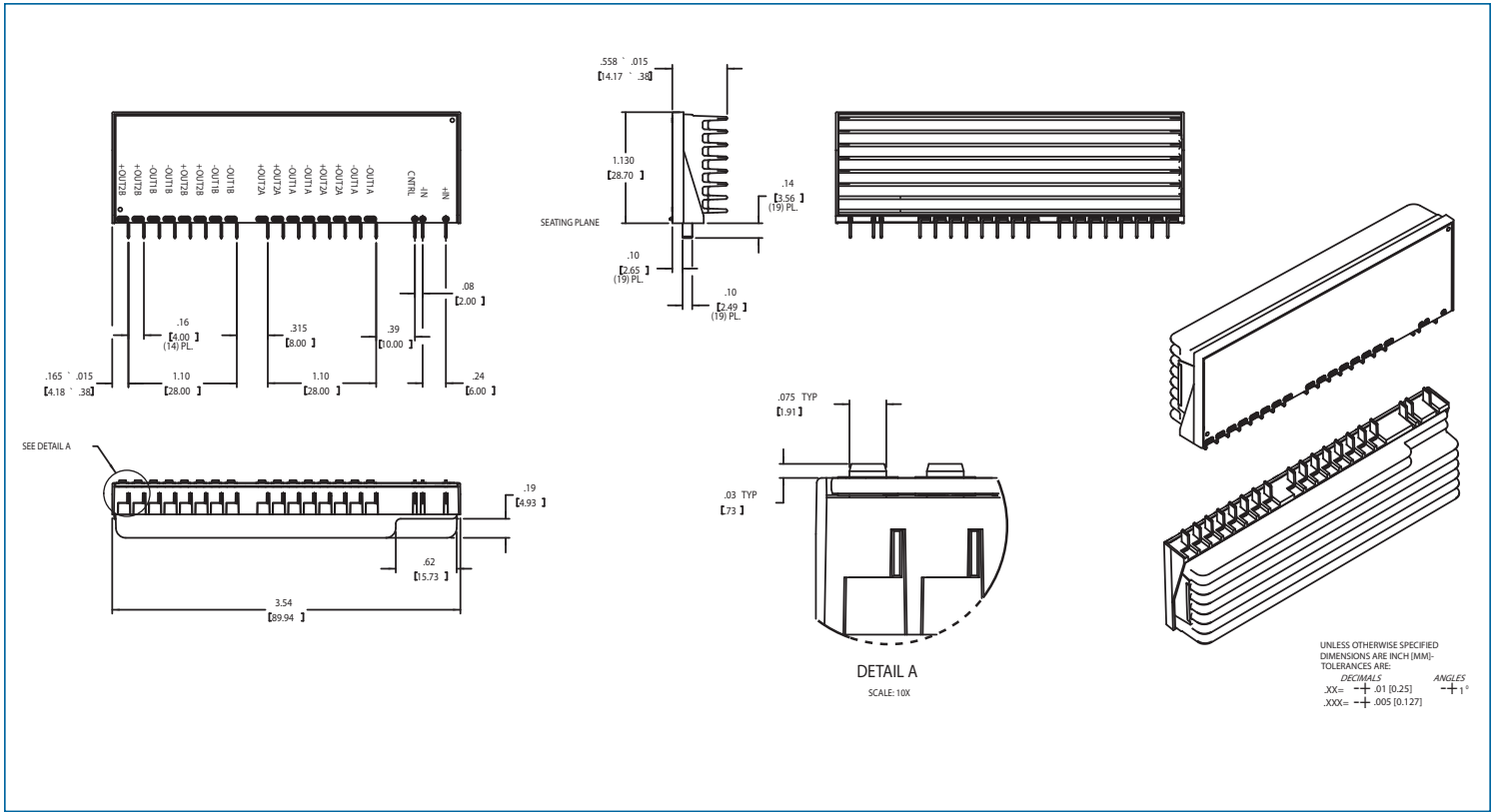

Figure 3 – BC352R110T030VM-00 mechanical outline

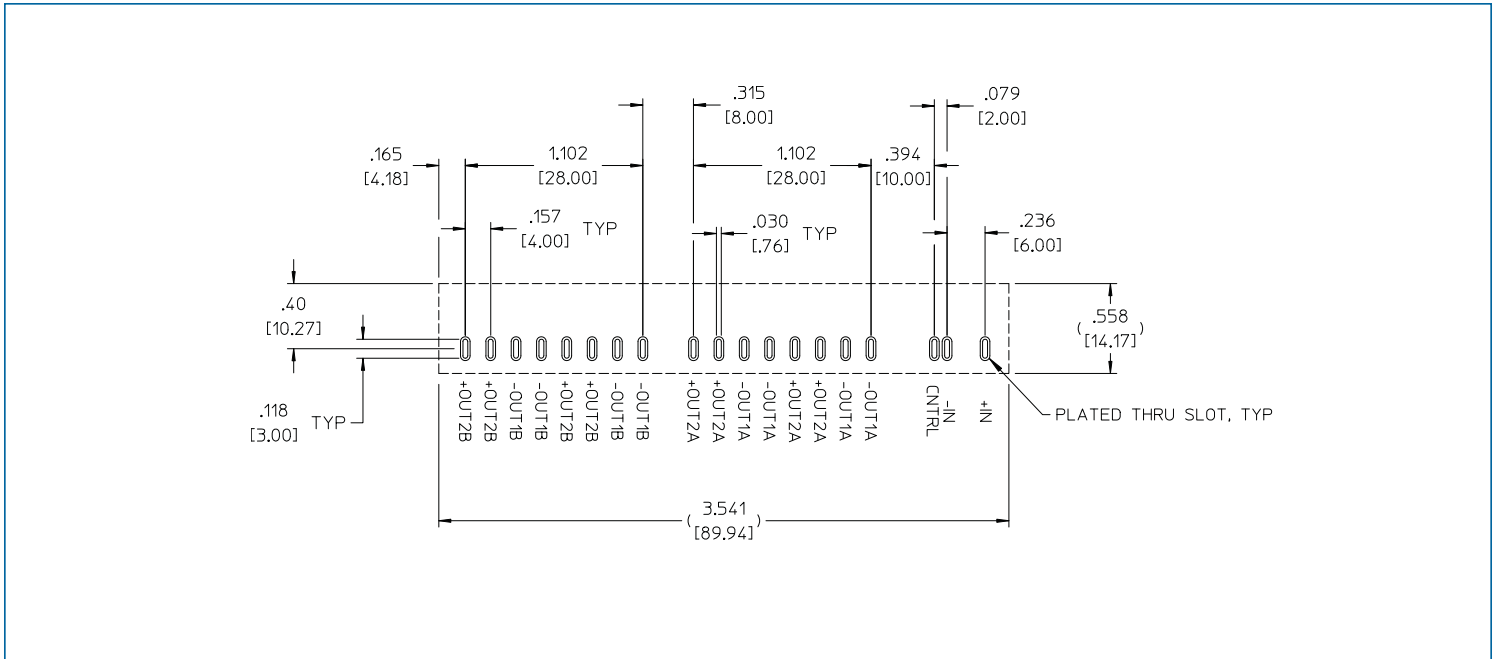

Figure 4 – BC352R110T030VM-00 footprint

## Warranty

Vicor products are guaranteed for two years from date of shipment against defects in material or workmanship when in normal use and service. This warranty does not extend to products subjected to misuse, accident, or improper application or maintenance. Vicor shall not be liable for collateral or consequential damage. This warranty is extended to the original purchaser only.

EXCEPT FOR THE FOREGOING EXPRESS WARRANTY, VICOR MAKES NO WARRANTY, EXPRESS OR IMPLIED, INCLUDING, BUT NOT LIMITED TO, THE WARRANTY OF MERCHANTABILITY OR FITNESS FOR A PARTICULAR PURPOSE.

Vicor will repair or replace defective products in accordance with its own best judgement. For service under this warranty, the buyer must contact Vicor to obtain a Return Material Authorization (RMA) number and shipping instructions. Products returned without prior authorization will be returned to the buyer. The buyer will pay all charges incurred in returning the product to the factory. Vicor will pay all reshipment charges if the product was defective within the terms of this warranty.

Information published by Vicor has been carefully checked and is believed to be accurate; however, no responsibility is assumed for inaccuracies. Vicor reserves the right to make changes to any products without further notice to improve reliability, function, or design. Vicor does not assume any liability arising out of the application or use of any product or circuit; neither does it convey any license under its patent rights nor the rights of others. Vicor general policy does not recommend the use of its components in life support applications wherein a failure or malfunction may directly threaten life or injury. Per Vicor Terms and Conditions of Sale, the user of Vicor components in life support applications assumes all risks of such use and indemnifies Vicor against all damages.

## **Vicor's comprehensive line of power solutions includes high density AC-DC and DC-DC modules and accessory components, fully configurable AC-DC and DC-DC power supplies, and complete custom power systems.**

Information furnished by Vicor is believed to be accurate and reliable. However, no responsibility is assumed by Vicor for its use. Vicor components are not designed to be used in applications, such as life support systems, wherein a failure or malfunction could result in injury or death. All sales are subject to Vicor's Terms and Conditions of Sale, which are available upon request.

## **Specifications are subject to change without notice.**

## **Intellectual Property Notice**

Vicor and its subsidiaries own Intellectual Property (including issued U.S. and Foreign Patents and pending patent applications) relating to the products described in this data sheet. Interested parties should contact Vicor's Intellectual Property Department.

The products described on this data sheet are protected by the following U.S. Patents Numbers: 5,945,130; 6,403,009; 6,710,257; 6,788,033; 6,940,013; 6,969,909; 7,038,917; 7,154,250; 7,166,898; 7,187,263; 7,202,646; 7,361,844; 7,368,957; RE40,072; D496,906; D506,438; D509,472; and for use under U.S. Pat. Nos. 6,975,098 and 6,984,965

**Vicor Corporation**  
25 Frontage Road  
Andover, MA, USA 01810  
Tel: 800-735-6200  
Fax: 978-475-6715

### email

Customer Service: [custserv@vicorpower.com](mailto:custserv@vicorpower.com)  
Technical Support: [apps@vicorpower.com](mailto:apps@vicorpower.com)