

# High Voltage BCM Series Array Evaluation System

<b>Contents</b>	<b>Page</b>
<b>1.0 Introduction</b>	<b>1</b>
1.1 Note on System Components	1
1.2 Features	1
<b>2.0 Evaluation System Description</b>	<b>2</b>
2.1 High Voltage BCM Series Array	
2.1.1 Power Rating of BCM array	
2.1.2 HV BCM Series Array Components	3
2.1.3 HV BCM Series Array Schematic	4
2.1.4 HV BCM Series Array Layout	5
2.2 HV BCM Series Evaluation Board	6
2.2.1 High Voltage Series Evaluation Baseboard Components	
2.2.2 High Voltage Series Evaluation Baseboard Schematic	7
2.2.3 High Voltage Series Evaluation Baseboard Layout	
2.3 HV BCM Series Array System Bill of Material	8
2.3.1 HV BCM Series Array Bill of Material	
2.3.2 HV BCM Evaluation Baseboard Bill of Material	
<b>3.0 Using the High Voltage BCM Series Array Evaluation System</b>	<b>8</b>
3.1 Warning	
3.2 Mounting Heat Sinks	9
3.3 Array / Baseboard Interface	
3.4 Load Connection	11
3.3 Line Connection	
3.4 Power Up Procedure	
3.5 Evaluation System Basic DO's & DON'ts	
<b>4.0 Basic Laboratory Test Procedures</b>	<b>12</b>
4.1 Measuring Efficiency	
4.2 Output Voltage Ripple	13
4.3 Enable / Disable Timing	14
4.4 Thermal Testing	16
<b>5.0 Conclusion</b>	<b>17</b>

## Warning

**Read all precautions throughout the guide BEFORE using the High Voltage BCM Series Array Evaluation System. Do not operate the High Voltage BCM Series Array Evaluation System unless you have the appropriate safety precautions in place on your bench to guarantee safety. The user's guide is not comprehensive and is not a substitute for common sense and good practice.**

## 1.0 Introduction

The High Voltage BCM Array System is a two piece evaluation system for powering, testing, and using high voltage input V.I Chip BCMs in a high power array. The system includes a vertical mounted card containing up to 4 BCMs connected with inputs in parallel and outputs in series as well as a horizontal mounted baseboard with a mating connector for the array board. The Evaluation System baseboard enables the testing of any compatible array boards and simplifies the connection of the input source and output load to the array.

### 1.1 Note on System Components

The High Voltage BCM Series Array Evaluation System contains two components:

**High Voltage BCM Series Array** refers to the vertical mounted card containing 4 BCMs (two on either side), as shown in Figure 1.

**High Voltage BCM Series Evaluation Baseboard** refers to the horizontal mounted card containing the mating connector for the array board and the input and output lug connections as shown in Figure 6.

### 1.2 Features

The High Voltage BCM Series Array Evaluation System contains the following:

- High Voltage BCM Series Array containing 4 BCMs for 1.2 kW total power
- High current output interconnect for >25 A of output current carrying capability
- Kelvin connections for measuring the efficiency of the V.I Chip components independent of load connect losses
- Oscilloscope probe jacks for measuring output voltage, including output voltage ripple
- Optional pads for ceramic capacitors for evaluating output filtering
- Fused BCM inputs
- Provision for mounting optional V.I Chip pushpin heat sinks
- System enable and disable
- Output power present indicators

The BCM series array provides the following features:

- High efficiency (> 95%) DC-DC voltage transformation
- Full line isolation 4,242 Vdc
- PFC compatible (360 – 400 Vdc) input capability
- Isolated 48 V output for powering PRMs, BCMs or other 48 V loads
- Auxiliary 12 V output for direct 12 V loads and lower power non-isolated point-of-load regulators

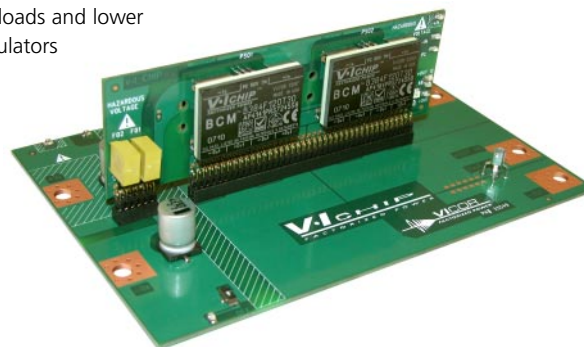

## 2.0 Evaluation System Description

### 2.1 The High Voltage BCM Series Array

The High Voltage BCM Series Array contains 4 High Voltage B384F120T30 BCMs

Please refer to the BCM data sheet for product-specific information regarding the operation and maximum ratings of the individual BCMs in the array. The data sheets can be found online at [vicorpower.com/technical\\_library/datasheets/](http://vicorpower.com/technical_library/datasheets/)

#### 2.1.1 Power Rating of BCM Series Array

The power rating of an array of BCMs is equal to the power rating of the individual BCM times the number of BCMs in an array.

The total output power capacity of the series BCM array 48 V output will be de-rated in the presence of 12 V output load. Summation of load currents connected to 48 V output and 12 V output should not exceed 25 A.



2.1.2 High Voltage BCM Series Array Components

Figure 1  
High Voltage BCM  
Series Array  
(front)

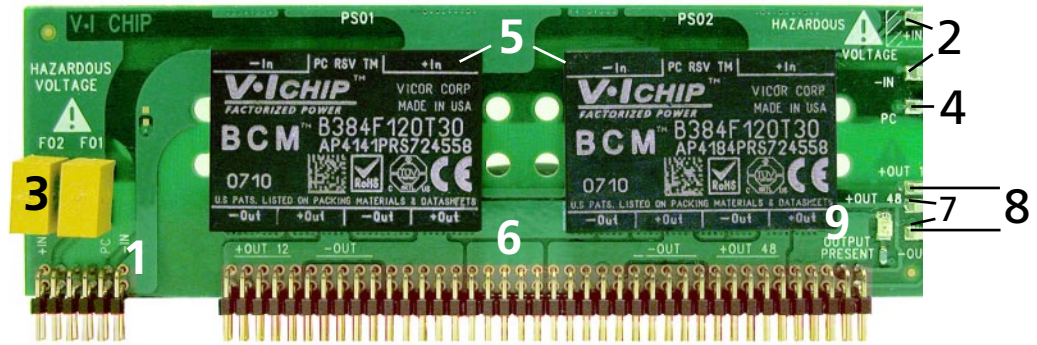

Figure 2  
High Voltage BCM  
Series Array  
(back)



Please refer to *Figure 1* and *2* for the High Voltage BCM Series Array components.

1. **Input Connector (J01).** Connects to +In and -In on the BCM array. Provides input power. Also brings PC connection from the BCM array to the baseboard.
2. **Input Kelvin Test Points (TP02, TP03).** Provides a voltage measurement directly on the input of the BCM array to enable an accurate efficiency measurement of the V•Chips.
3. **Fuses (F01, F02).** These are High Voltage DC UL listed fuses, which provide fault protection to the board. F01 fuses PS01 and PS02. F02 fuses PS03 and PS04.
4. **PC Kelvin Test Point (TP05).** Test point for PC signal. This signal serves as a fault flag for the HV series BCM system as well as an enable / disable signal.
5. **BCMs (PS01, PS02, PS03, PS04).** These are the BCM V•Chip components that provide the DC-DC transformation, and isolation of the input power.
6. **Output Connector (J02).** Connects the 48 V Out and 12 V outputs to the baseboard. Contains Kelvin pins for baseboard test points.
7. **Output Kelvin Test Points for 48 V (TP01, TP04).** Provides a voltage measurement directly on the output of the BCM array to enable an accurate efficiency measurement of the V•Chips.
8. **Output Kelvin Test Points for 12 V (TP04, TP06).** Provides a voltage measurement directly on the output of the BCM array to enable an accurate efficiency measurement of the V•Chips.
9. **Output Present LED for 48 V (D01, D02).** Lights green when output voltage is present. Provides visual indication of BCM array operation.

### 2.1.3 High Voltage BCM Series Array Schematic

Figure 3  
High Voltage BCM  
Series Array  
schematic

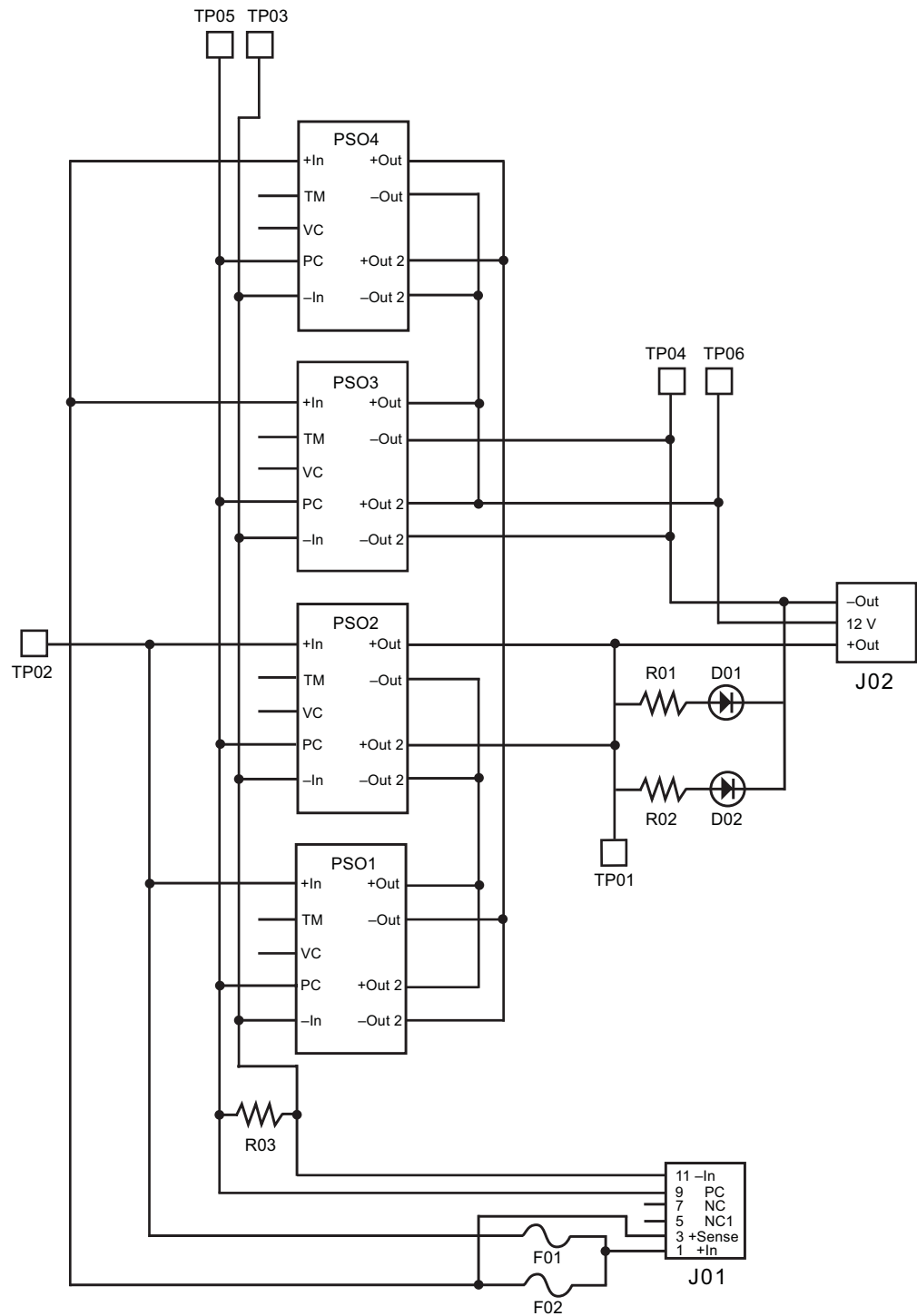

### 2.1.4 High Voltage BCM Series Array Layout

Figure 4  
High Voltage BCM  
Series Array layout  
(top)

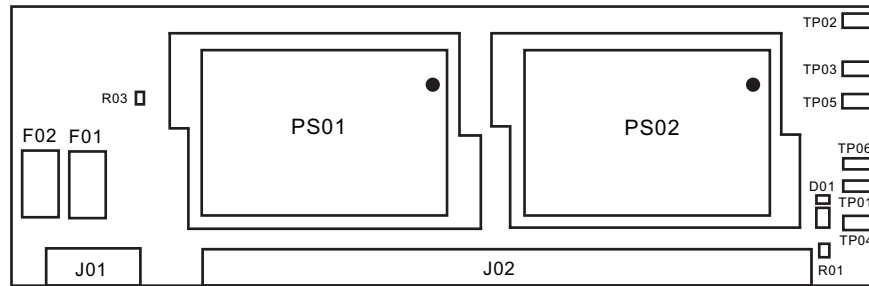

Top View

Figure 5  
High Voltage BCM  
Series Array layout  
(bottom)

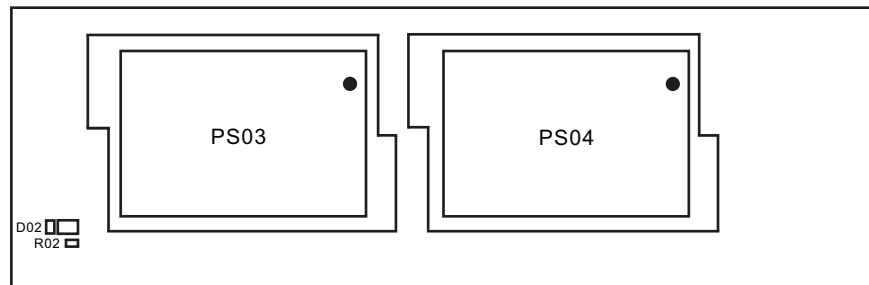

Bottom View

## 2.2 High Voltage BCM Series Evaluation Baseboard

The High Voltage BCM Series Evaluation Baseboard enables laboratory evaluation of the High Voltage BCM Series Array. It provides a stable horizontal base for the vertical array card to plug in as well as source and load interconnect lugs, scope probe jacks, and Kelvin test points for input and output voltage measurement. It also contains an enable / disable switch that toggles the array PC signal.

### 2.2.1 High Voltage Series Evaluation Baseboard Components

Figure 6  
High Voltage BCM  
Series Evaluation Baseboard  
component placement

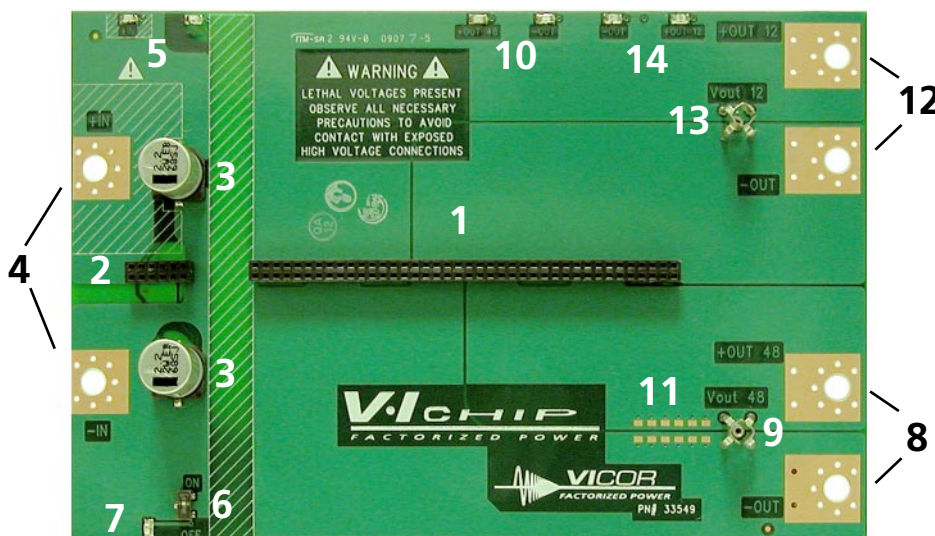

1. **Array Output Socket (J02).** Interfaces with the output connector on the High Voltage BCM Series Array.
2. **Array Input Connector (J01).** Interfaces with the input connector on the High Voltage BCM Series Array.
3. **Input Capacitors (C01, C02).** Provides low AC impedance at the input of the array. This enables the performance of the array to be essentially independent of the upstream source impedance, allowing longer connection wires to be used between the source and baseboard for bench top evaluation purposes.
4. **Input Source Lugs (H1, H2).** Connect the High Voltage source (DC supply or PFC front-end output) here.
5. **Input Kelvin Test Points (TP01 TP02).** Kelvin connections to the input of the BCM array enable accurate efficiency measurements of the V•I chips independent of interconnect losses.
6. **Array enable / disable switch (SW01).** This switch toggles the PC signal for the array. With the switch in the "UP" position, the PC is floating and the array is enabled. With the switch in the "DOWN" position, the PC is connected to -In and the array is disabled.
7. **PC (TP03).** Test point for PC signal. This signal serves as a fault flag for the series BCM system as well as an enable / disable signal.
8. **Output Load Lugs for 48 V (H3, H4).** Connect the 48 V load here (resistor bank, motherboard, or electronic load).
9. **Output Voltage Oscilloscope Probe Jack for 48 V (J03).** Accepts most oscilloscope probes and enables precision measurement of the output voltage ripple.
10. **Output Kelvin Test Points for 48 V (TP04, TP07).** Kelvin connections to the 48 V output of the BCM array to enable accurate efficiency measurements of the V•I Chips independent of interconnect losses.
11. **Pads (C03 to C08).** 1206 size pads for ceramic capacitors for evaluating 48 V output filtering.
12. **Output Load Lugs for 12 V (H5, H6).** Connect the 12 V load here (resistor bank, motherboard, or electronic load).
13. **Output Voltage Oscilloscope Probe Jack for 12 V (J04).** Accepts most oscilloscope probes and enables precision measurement of the output voltage ripple.
14. **Output Kelvin Test Points for 12 V (TP05, TP06).** Kelvin connections to the 48 V output of the BCM array enable accurate efficiency measurements of the V•I Chips independent of interconnect losses.

### 2.2.2 High Voltage BCM Series Array Baseboard Schematic

Figure 7  
High Voltage  
BCM Series Array  
baseboard schematic

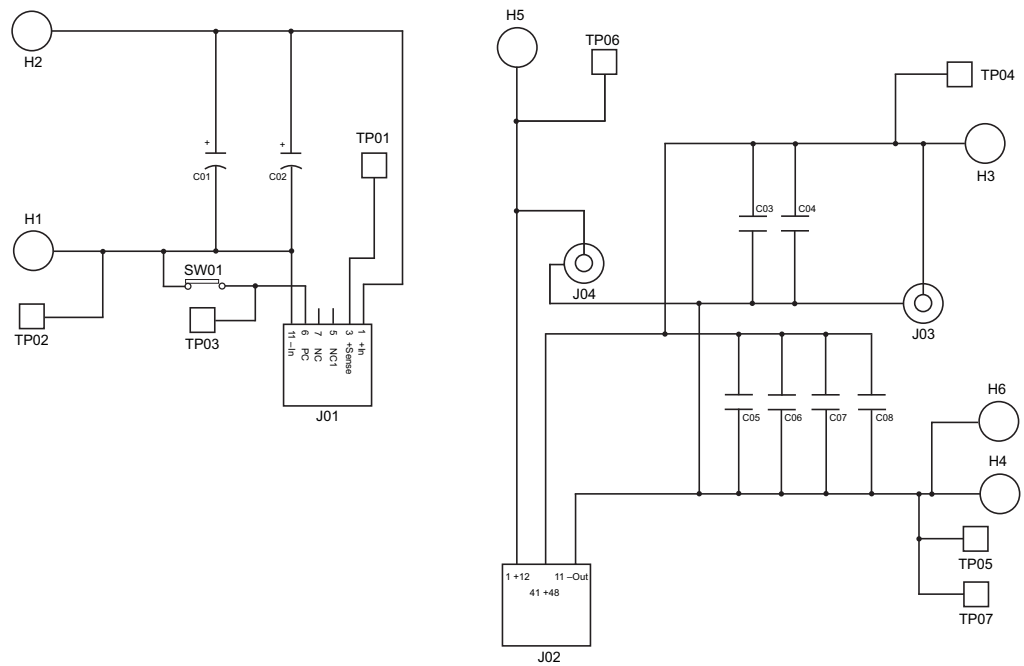

### 2.2.3 High Voltage BCM Series Array Baseboard Layout

Figure 8  
High Voltage BCM  
Series Array baseboard layout

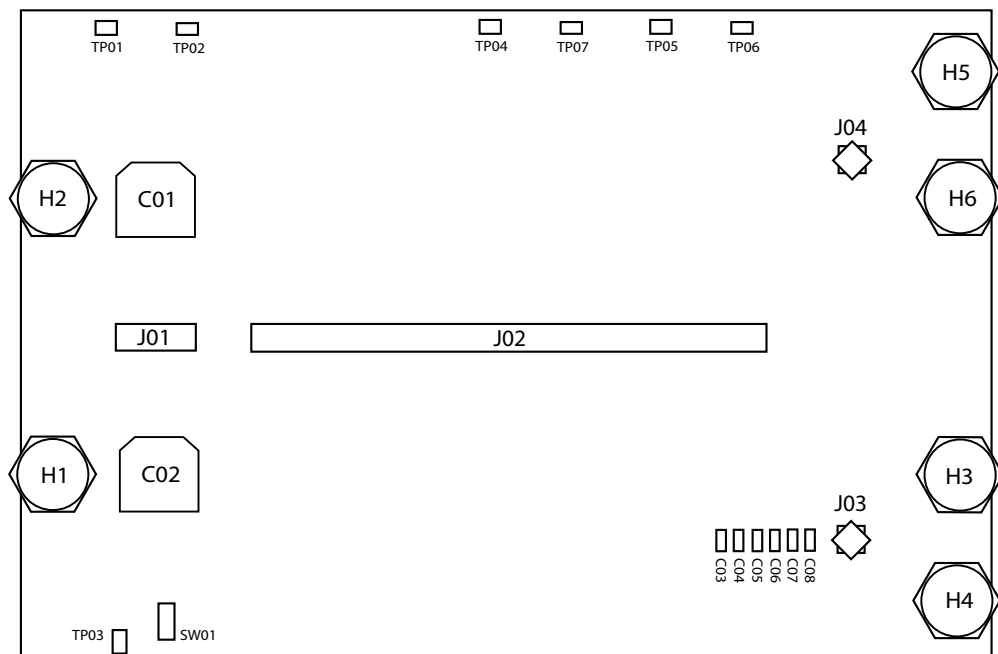

## 2.3 High Voltage BCM Series Array System Bill of Material

### 2.3.1 High Voltage BCM Series Array Bill of Material

Item No.	Description	Ref. Des.	Vicor PN	Vendor	Vendor PN
1	HV 4 BCM Series Array main board	PCB	33379		
2	B384F120T30 V•I Chip BCM	PS1	B384F120T30		
3	B384F120T30 V•I Chip BCM	PS2	B384F120T30		
4	B384F120T30 V•I Chip BCM	PS3	B384F120T30		
5	B384F120T30 V•I Chip BCM	PS4	B384F120T30		
6	2.5 A / 450 Vdc fuse	F01	08395		
7	2.5 A / 450 Vdc fuse	F01	08395		
8	Res 40.2 K Ohm 1/10 W 1% 0603	R01	15462-4022		
9	Res 40.2 K Ohm 1/10 W 1% 0603	R02	15462-4022		
10	Res 274 Ohm 1/10 W 1% 0603	R03		Mouser	660-RK73H1JTTD2740F
11	Clear green SMT LED 1206	D01		Digikey	67-1698-1-ND
12	Clear green SMT LED 1206	D02		Digikey	67-1698-1-ND
13	12 pin right angle connector	J01		Digikey	S5803-06-ND
14	80 pin right angle header	J02		Digikey	S5803-04-ND
15	Test point surface mount	TP01	27995		
16	Test point surface mount	TP02	27995		
17	Test point surface mount	TP03	27995		
18	Test point surface mount	TP04	27995		
19	Test point surface mount	TP05	27995		
20	Test point surface mount	TP06	27995		

### 2.3.2 High Voltage BCM Series Evaluation Baseboard Bill of Material

Item No.	Description	Ref. Des.	Vicor PN	Vendor	Vendor PN
1	HV 4 BCM Series Array baseboard	PCB	33549		
2	12 pin right angle receptacle	J01		Digikey	S5750-06-ND
3	80 pin right angle receptacle	J02		Digikey	S5750-40-ND
4	Cap Al-EL 2.2 $\mu$ F 450 V	C01	28506-225		
5	Cap Al-EL 2.2 $\mu$ F 450 V	C02	28506-225		
6	Test Point surface mount	TP01	27995		
7	Test point surface mount	TP02	27995		
8	Test point surface mount	TP03	27995		
9	Test point surface mount	TP04	27995		
10	Test point surface mount	TP05	27995		
11	Scope Jack Tektronix	J04	16949		
12	Scope Jack Tektronix	J03	16949		
13	Not used	C03			
14	Not used	C04			
15	Not used	C05			
16	Not used	C06			
17	Not used	C07			
18	Not used	C08			
19	SPST SMD switch	SW01		Digikey	563-1021-1-ND
20	Test point surface mount	TP06	27995		
21	Test point surface mount	TP07	27995		

## 3.0 Using the High Voltage BCM Series Array Evaluation System

### 3.1 Warning

Read the precautions below entirely **BEFORE** using the High Voltage BCM Series Array Evaluation System. Do not operate the High Voltage BCM Series Array Evaluation System unless you have the appropriate safety precautions in place on your bench to guarantee safety. **Hazardous Voltages are present on the High Voltage BCM Series Array Evaluation System under power. PERSONAL CONTACT WITH LINE VOLTAGE MAY RESULT IN SEVERE INJURY, DISABILITY, OR DEATH. IMPROPER OR UNSAFE HANDLING OF THIS BOARD MAY RESULT IN SERIOUS INJURY OR DEATH.** The list below is not comprehensive and is not a substitute for common sense and good practice.

1. **ALWAYS** remove power before touching, servicing, or attaching probes to the system. Verify that the power is removed before touching. Physically disconnect input power or use a lockout / tagout (LOTO) system to prevent the accidental application of power while servicing the system.

2. The system is designed to demonstrate the use of BCM's in offline systems, for general laboratory evaluation. It is highly recommended for safety purposes to use an isolated high voltage source. This source can be a benchtop regulated high-voltage DC source, or an offline PFC front-end powered through an ISO-VAC or line isolation transformer.
3. **NEVER** leave the system unattended when under power.
4. **DO NOT** allow other people to work in the vicinity of the High Voltage BCM Series Array Evaluation System under power.
5. Provide strain relief for wires and place the system on the bench in such a way as to prevent accidental dislodgement from the bench top. Connecting wires or attached probes should not hang off the bench.
6. **NEVER** probe the input of the system with a non-isolated oscilloscope probe unless **absolutely sure** of whether or not the input is line isolated.
7. **USE** appropriate shielding of exposed high voltage areas of the system to prevent accidental casual contact. Please refer to Figure 9, 10, 11 for a map of the exposed high voltage areas on both sides of the board.

Figure 9  
Exposed hazardous voltage  
High Voltage BCM Array  
top

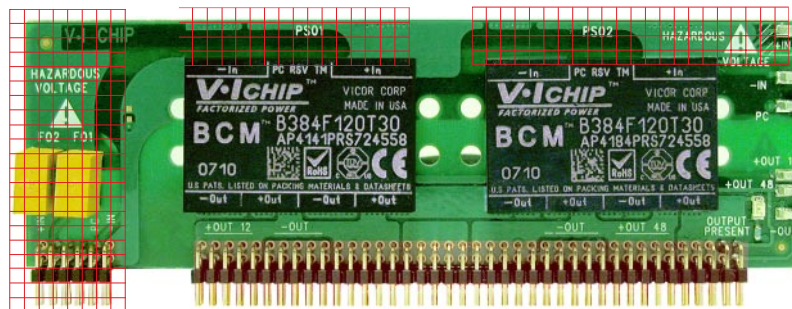

Figure 10  
Exposed hazardous voltage  
High Voltage BCM Array  
bottom

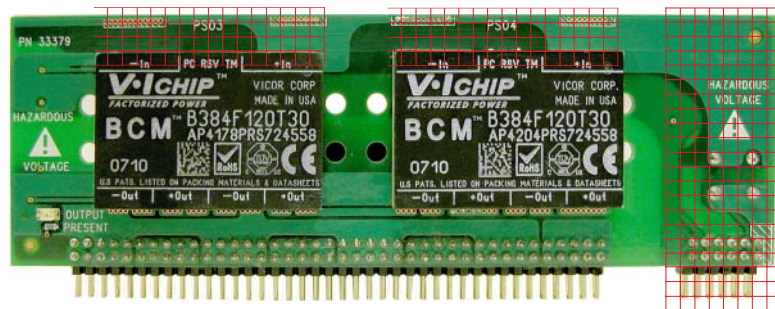
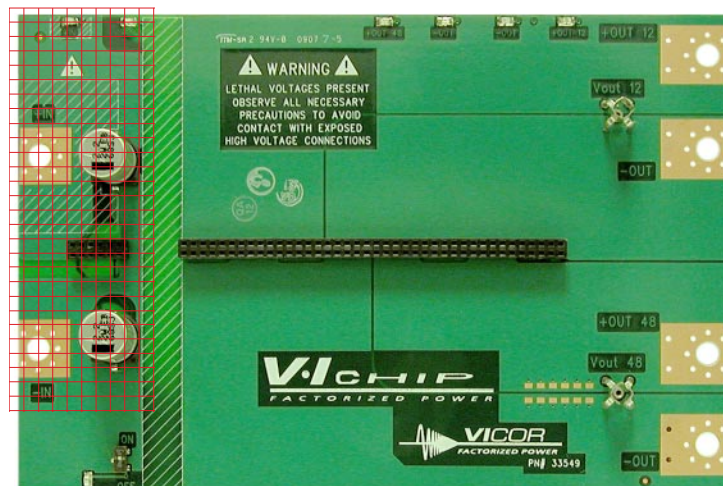

Figure 11  
Exposed hazardous voltage  
High Voltage evaluation  
baseboard



8. **NEVER** jumper across the fuses. Replace fuses only with fuses of equivalent type and rating.
9. The High Voltage BCM Series Array Evaluation System is designed for use in a laboratory environment. Use of the system in other environments is not recommended. The Baseboard should always be mounted to a flat surface, and wired in such a way that it rests firmly on the bench top.
10. **DO NOT** attempt to wire or use the High Voltage BCM Series Array without the baseboard or an equivalent connector.
11. **NEVER** attempt to disconnect the array from the baseboard while power is applied. This system is not designed to demonstrate hot plug capability. Additional components would be required to implement a hot plug capable system.

### 3.2 Mounting Heat sinks

Pushpin V•I Chip heat sinks are included with the High Voltage BCM Series Array to allow extended benchtop testing at full power and lower airflow. Please follow the procedure below when mounting heat sinks to the BCMs.

1. Place the High Voltage BCM Series Array on a flat benchtop with the top side facing up. The board should be resting on the bottom BCMs. Verify that the board is flat, and there are no obstructions under the board or near the hole location.
2. Make sure the top of the BCMs are clean and free of dust or debris.
3. Place the first heat sink on top of the BCM and align the pushpins with the appropriate holes. Push lightly on the heat sink to engage the thermal interface with the case of the V•I Chip.
4. With the top of a pen press firmly on each pushpin until it engages in the hole. The pushpin should click and lock firmly into the hole. Do not force the pushpin, and do not apply more than 5 lb. pressure to engage the pin.
5. Repeat step #4 with the second heat sink on the top side.
6. Turn the High Voltage BCM Series Array over and repeat steps #2 – #5 for the remaining two heat sinks.

If, for any reason, the heat sinks need to be removed, cut the pushpins with a pair of snips or wire cutters. Do not attempt to preserve the pushpins for re-use. The heat sink pushpins can be replaced (please see the Vicor catalog for part numbers and ordering information) and the heat sink itself re-used if desired.

### 3.3 Array / Baseboard Interface

The High Voltage BCM Series Array connects to the High Voltage Evaluation Baseboard using a pair of standard 2 mm pitch pin connectors. The following guidelines should be followed when connecting and disconnecting the array from the baseboard.

**Improper handling of the High Voltage BCM Series Array Evaluation System can result in injury or death.**

1. The system should **always be powered off before attempting to connect or disconnect the array from the baseboard**. Input voltage should be removed (not disabled using the on / off switch). Always check to make sure that the system is off before disconnecting the two components.
2. To connect the array, align the pins of the array with the sockets on the baseboard. With one hand on either end of the board apply direct downward pressure on the array and push the pins evenly into the sockets. **Do not force the array pins into the socket**. More pressure will need to be applied to the output end of the array due to the fact that there are more pins on that side of the board. Do not insert the array into the socket by applying pressure on the BCMs; apply force directly to the board.
3. To remove the array, with one hand hold the baseboard firmly to the bench top surface. With the other hand, grip the array close to the connector and ease it up slightly on one end. Repeat this on the other end. Keep edging the array slowly out of the connector end by end until the connection loosens and the array can be easily lifted out.

### 3.4 Load Connection

Note: Please refer to the BCM data sheet specifications for the applicable ratings (Input, Output Power for single BCM, voltage, etc.)

**For 48 V output:** Connect a resistor, motherboard, or electronic load, capable drawing rated power of the BCM array to + Out 48 and –Out of the baseboard (locations shown in Figure 6 and 8).

The array will operate correctly at no load.

The output voltage may be monitored using an oscilloscope probe placed in scope jack marked with label Vout 48 (J03) (Figure 6 and 8).

**For 12 V output:** Connect a resistor, motherboard, or electronic load, capable drawing rated power of a single BCM to + Out 12 and –Out of the baseboard (locations shown in Figure 6 and 8).

The array will operate properly at no load.

The output voltage may be monitored using an oscilloscope probe placed in scope jack marked with label Vout 12 (J04) (Figure 6 and 8).

### 3.3 Line Connection

**Improper handling of the High Voltage BCM Series Array Evaluation System can result in injury or death.**

Connect an DC power source capable of providing at least 115% of the rated power of the BCM array to +In and –In of the, shown in Figure 6.

**Note:** Verify that all connections are made properly before applying power.

Once power is applied to the board, lethal voltages are present. Necessary precautions should be taken to avoid injury.

The use of an AC isolation transformer when using a non-isolated PFC front-end is highly recommended.

### 3.4 Power Up Procedure

**Improper handling of the High Voltage BCM Series Array Evaluation System can result in injury or death.**

Apply DC voltage to the High Voltage BCM Series Array Evaluation System and verify that there is an output voltage as expected. DC voltage may be applied directly by switch action, or powered up slowly using a high voltage adjustable DC source.

### 3.5 Evaluation System Basic DO's and DON'ts

**Improper handling of the High Voltage BCM Series Array Evaluation System can result in injury or death.**

**DO** observe necessary safety precautions when using the evaluation system at all times.

**DO** keep a fan blowing on the High Voltage BCM Series Array Evaluation System when running for extended periods of time at high load, and be mindful that the heat sinks may be hot.

**DO** keep wires, probes, jumpers, etc. well contained and fixed when using the High Voltage BCM Series Array Evaluation System.

**DO NOT** attempt to tamper with, replace, or change components on the High Voltage BCM Series Array Evaluation System.

**DO NOT** probe, connect, or disconnect wires on the High Voltage BCM Series Array Evaluation System while line voltage is applied.

**DO NOT** exceed any of the input and output ratings of the BCM array as specified in the single BCM data sheet. If unsure about whether or not a procedure is acceptable, please contact Vicor Applications Engineering for assistance.

## 4.0 Basic Laboratory Test Procedures

This section will cover some basic test procedures for acquiring evaluation data using the High Voltage BCM Series Array Evaluation system.

### 4.1 Measuring Efficiency

The High Voltage BCM Series Array evaluation system is equipped with input and output Kelvin connections to facilitate efficiency measurements. The following procedure should be followed to measure efficiency.

1. Connect input voltage measurement leads to Kelvin test points + In (TP01) and –In (TP02) that located on baseboard. Observe correct polarity as marked.
2. Connect output voltage measurement leads to Kelvin test points +Out 48 (TP04) and –Out (TP07) that located on baseboard. Observe correct polarity as marked.
3. Insert a calibrated shunt in series with the –In lug connection. The shunt should be capable of measuring up to approximately 5 A of current.
4. Insert a calibrated shunt in series with the –Out lug connection. This shunt should be capable of measuring up to approximately 30 A of current.
5. Power the unit on.
6. Enable the unit using the array enable / disable switch.
7. Choose an appropriate temperature for taking the efficiency data and allow the unit to equilibrate to that temperature. If necessary, run the unit with some load to increase the rate of temperature rise.
8. Once equilibrated, set the load to the appropriate value. Take input voltage, current, output voltage and current measurements and disable the unit using array enable / disable switch.
9. Repeat steps 6 to 8 for the desired range of load values.
10. Determine the efficiency (in %) per the equation below:

$$\text{Efficiency} = \frac{V_{\text{out}} \cdot I_{\text{out}}}{V_{\text{in}} \cdot I_{\text{in}}} \cdot 100$$

Figure 12 shows efficiency data for a 0 – 1.2 kW load at 40°C case temperature with heat sinks.

Figure 12  
System Efficiency

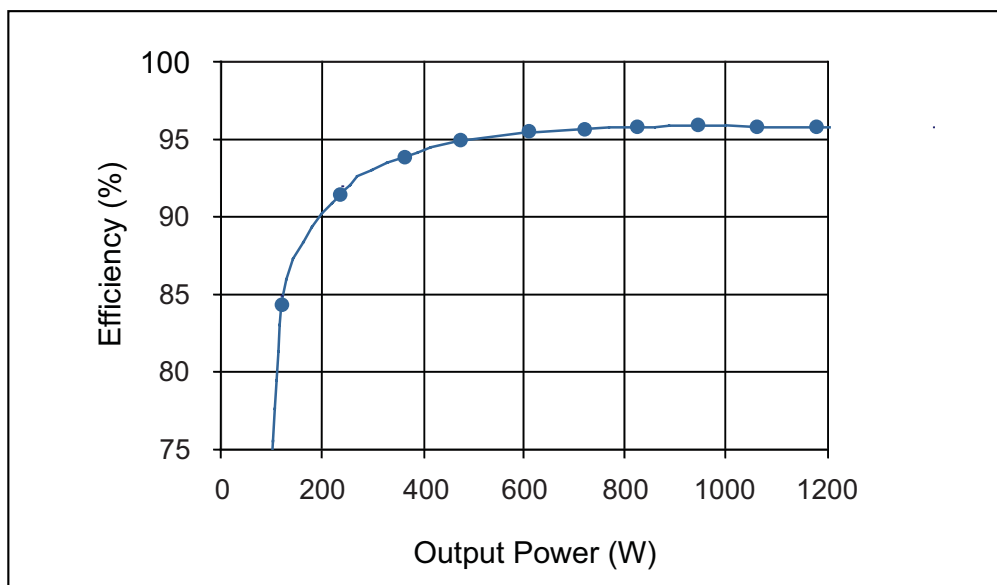

### 4.2 Output Voltage Ripple

J03 should be used for output voltage ripple measurements to minimize inductive noise pickup. To measure ripple, insert the scope probe into J03 (for 48 V), apply power to system, set the load, and trigger the oscilloscope on the ripple. The BCM switches at approximately 1.5 MHz. Due to the rectification of the internal sinusoidal oscillator, the output voltage ripple appears at twice the switching frequency, approximately 3 MHz. Please see Figure 13.

Figure 13  
48 V output voltage ripple at 25 A out

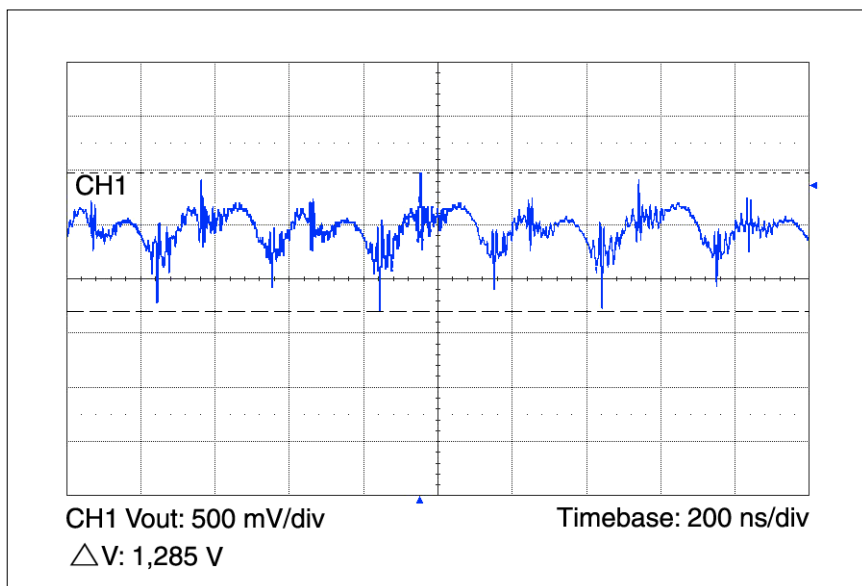

It is important to keep in mind that the BCM is an ideal voltage transformer at frequencies below 1 MHz and ripple voltage that appears on the input will appear on the output as well, reduced by the K factor. This is especially important in systems where the BCM array is powered from a PFC front-end. The 120 Hz ripple component of the PFC front-end will appear on the output of the BCM reduced by its K-factor (in this case, 1/32).

Ceramic capacitors can be added in positions C03 – C8 to reduce the output voltage ripple (Figure 14).

Figure 14  
48 V output voltage ripple at 25 A out with 12  $\mu F$  ceramic output capacitance

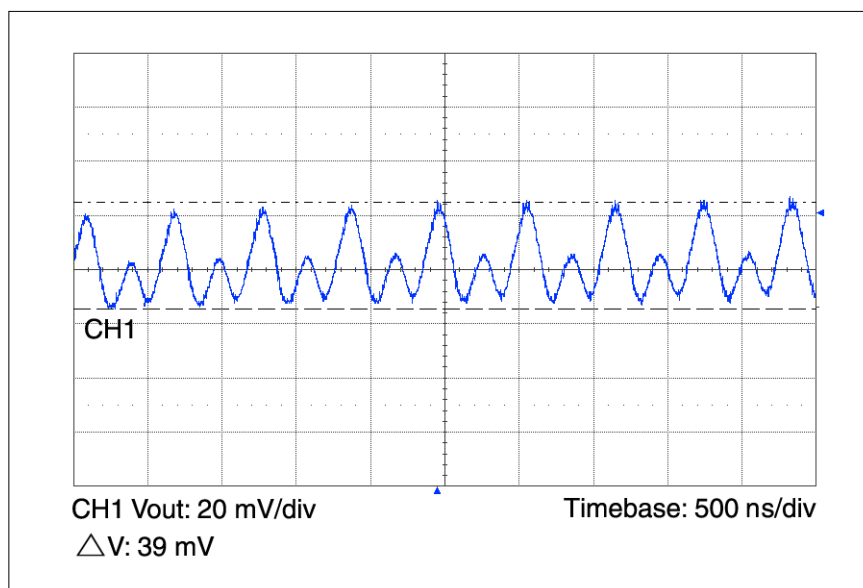

Finally, given that this is a series array of BCMs, each BCM switches at a slightly different frequency. The actual differences in switching frequency are minute, but will result in a low frequency beat that is visible on the output (Figure 15). The beat frequency is best attenuated by filtering each BCM output individually — by attenuating the 3.0 MHz ripple, the beat frequency is proportionally attenuated. In an array of 4 BCMs, the beat frequencies are never more than 4x the amplitude of an individual BCM ripple, making individual filtering the most effective approach in serial array applications.

Figure 15  
48 V output voltage ripple  
BCM array using B384F120T30  
modules at 25 A out with 12  $\mu$ F  
ceramic output capacitance,  
showing beat frequencies

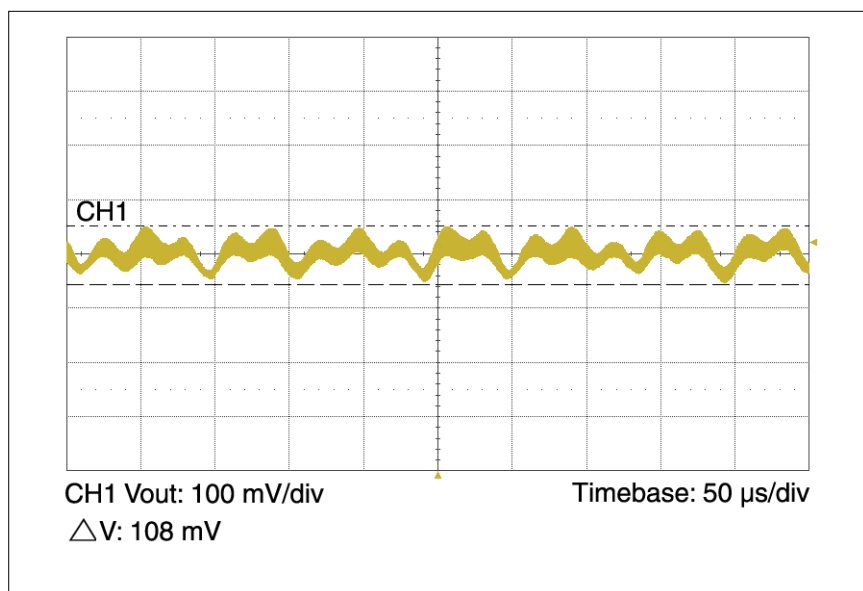

### 4.3 Enable / Disable Timing

Figure 16 and 17 illustrate the basic timing between output voltage rise and release of PC, or application of input power.

Figure 16  
Output voltage rise time  
on PC enable

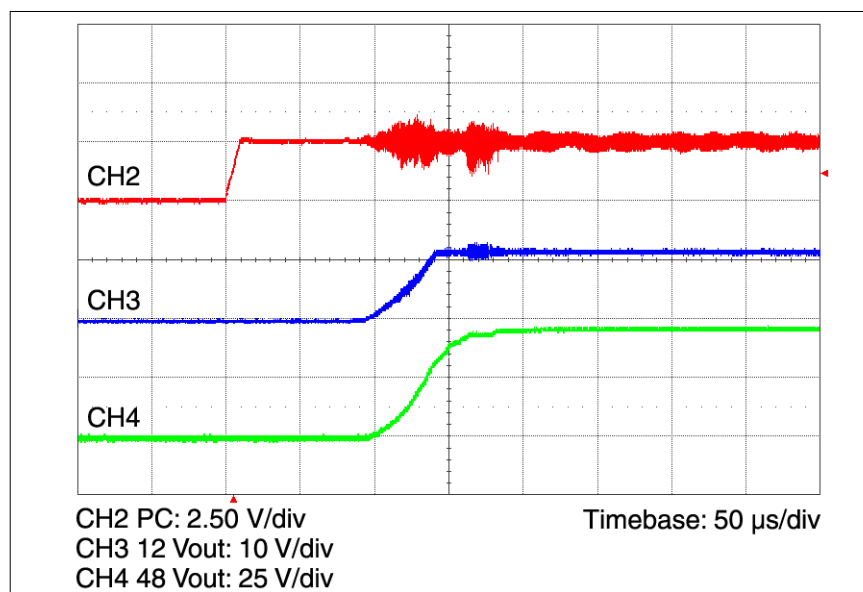

Figure 17  
Output voltage rise time after application of input power

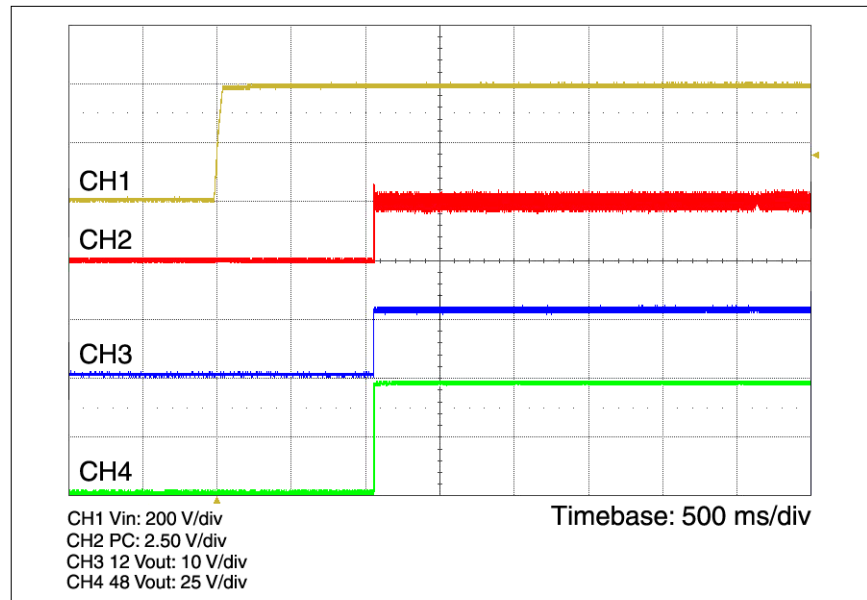

Figure 18 illustrates the basic timing between output voltage fall and release of PC.

Figure 18  
Output voltage fall time on PC disable

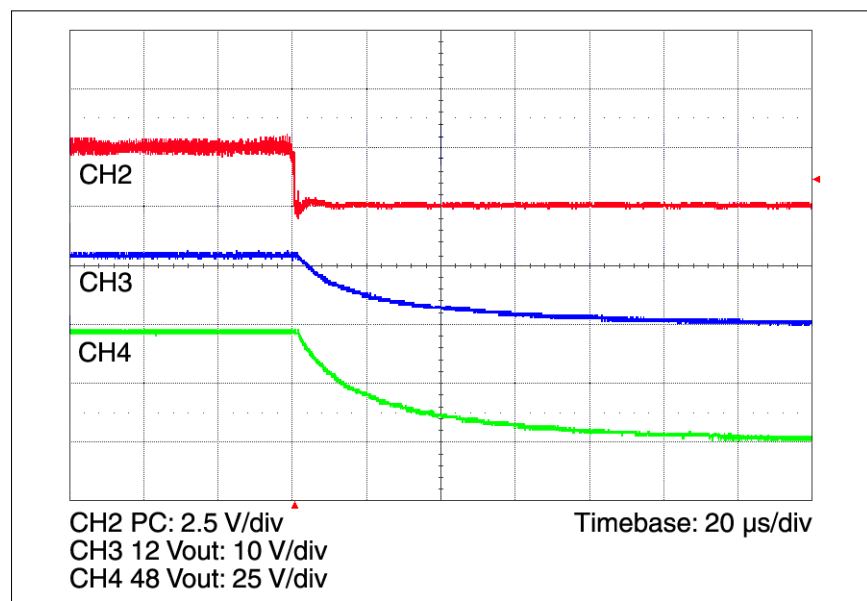
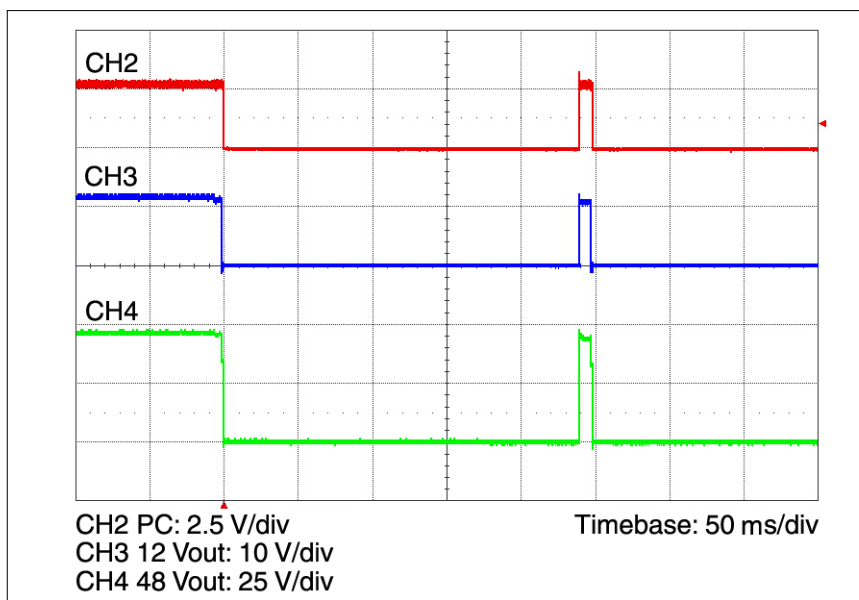

Figure 19 illustrates the output voltage and PC waveform during a fault condition such as overvoltage, undervoltage, or over current, on one of the BCMs. When a fault occurs on one of the BCMs, the 274 Ω resistor connected between PC and -In disables each BCM by bringing down the PC voltage below 2.4 V. Under normal operating condition PC voltage is between 2.5 V and 2.9 V.

Figure 19  
Output voltage  
under fault condition



#### 4.4 Thermal Testing

As with any high-density power system, it is important to design a robust thermal management system which adequately cools the system under all ambient conditions. The High Voltage BCM Series Array has high power density but it also has a relatively high-heat density. The BCMs dissipate approximately 15 W each at full load and the interconnect losses are approximately 1.2 W at 25 A. This section will discuss some details of cooling a vertical mount product.

The BCM can be cooled via two paths, through the PCB to ambient, or through the case to ambient. For more details on the thermal management of the BCM, please see [AN:008](#). The High Voltage BCM Series Array does not enable any cooling through the PCB. This is due primarily to two factors; 1) the double-sided construction of the system and 2) the lack of copper on the primary (high voltage) side of the board. Thus virtually all of the cooling must be done through the case.

Since the array has two BCMs in line, inline cooling will provide one BCM with the cool inlet air, and the second BCM with heated air from the first BCM. The result is that one BCM may be substantially hotter than the other when employing inline cooling (Figure 20). There are ways to equalize the temperature between BCMs which include a) using different height heat sinks or b) blowing air orthogonal to the array. In the latter case, both sides of the board must be cooled separately.

Figure 20  
 Inline cooling of BCM array,  
 illustrating the temperature  
 difference between the first  
 and second V.I Chips, at 25 A,  
 25°C ambient with 400 lfm of  
 airflow (no ducting).

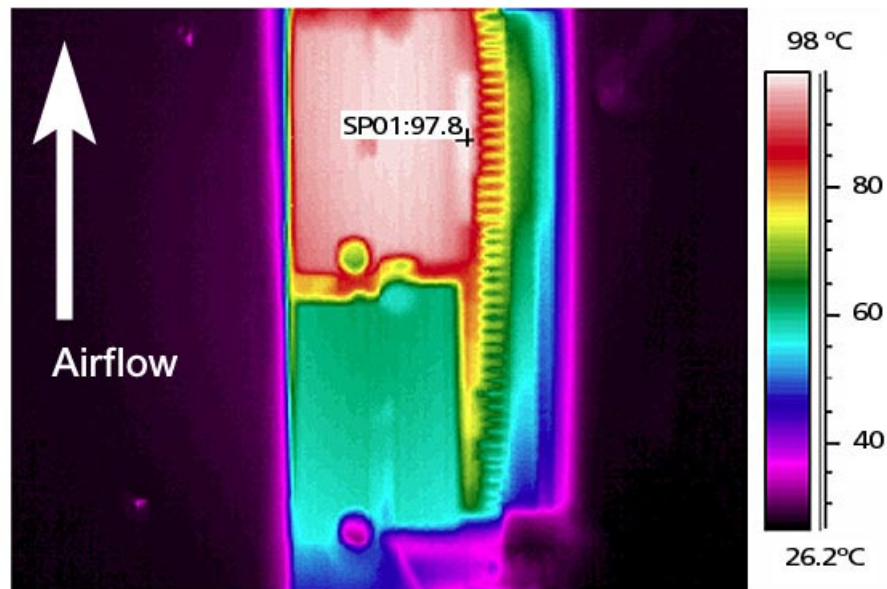

## 5.0 Conclusion

The High Voltage BCM Series Array system is ideal for evaluating the potential of using V.I Chips in post PFC or high voltage DC applications to power downstream regulators and niPOLs. If you require any additional assistance, or would like further design support, Vicor Applications Engineering is available to assist.

Technical advice furnished by Vicor is provided as a free service, with the intent to facilitate successful implementation of Vicor Products. Vicor assumes no obligation or liability for the advice given or results obtained.  
 All such advice given and accepted is at user's risk.

US Technical Support Center Tel: 800-927-9474 or email at [apps@vicr.com](mailto:apps@vicr.com)

France Support Center Tel: +33 1 34 52 18 30 or email at [vicorfr@vicr.com](mailto:vicorfr@vicr.com)

Germany Support Center Tel: +49 89 962 439 0 or email at [vicorde@vicr.com](mailto:vicorde@vicr.com)

Italy Support Center Tel: +39 02 2247 2326 or email at [vicorit@vicr.com](mailto:vicorit@vicr.com)

UK Support Center Tel: +44 1276 678222 or email at [vicoruk@vicr.com](mailto:vicoruk@vicr.com)

Hong Kong Support Center Tel: +852 2956 1782 or email at [hkapps@vicr.com](mailto:hkapps@vicr.com)

Japan Support Center Tel: +81 3 5487 5407 or email at [apps@vicr.co.jp](mailto:apps@vicr.co.jp)