

PFC MegaPAC

PFC MegaPAC-High Power™

Power Factor Corrected AC-DC Switchers



Design Guide

and

“Quick Install” Instructions



www.vicorpower.com

TABLE OF CONTENT

Overview of Product.....	3
Mechanical Considerations.....	4
MegaPAC Do's and Don'ts.....	4
Technical Description.....	5
Configuring and Reconfiguring MegaPACs.....	6
ConverterPAC Description.....	7
Part Numbering.....	8
ConverterPAC Output and Connector Pin Identification.....	9
Quick Install Instructions.....	10
Mechanical Drawings.....	12
Interface Connections.....	13
Specifications.....	18
Power Derating.....	20
Connector Kit Listing.....	21
Current Share Boards.....	22
Low Leakage Version.....	24
Output Sequencing.....	25

Mechanical Considerations

The PFC MegaPAC and PFC MegaPAC-High Power can be mounted on any of four surfaces using standard 8-32 or 4mm screws. The chassis comes with four mounting points on each surface; maximum allowable torque is 5.5 lb-in. The maximum penetration is 0.15 in. (3.8mm).

When selecting a mounting location and orientation, the unit should be positioned so air flow is not restricted. Maintain a 2" minimum clearance at both ends of the PFC MegaPAC and PFC MegaPAC-High Power and route all cables so airflow is not obstructed. The standard unit draws air in at the fan side/AC input side and exhausts air out the load side. If airflow ducting is used, use caution, as sharp turns could present back pressure to the PFC MegaPAC and PFC MegaPAC-High Power. The fan moves approximately 30 CFM of air.

Avoid excessive bending of output power cables after they are connected to the PFC MegaPAC and PFC MegaPAC-High Power. For high-current outputs, use cable ties to support heavy cables in order to minimize mechanical stress on output studs. Be careful not to short-out to neighboring output studs. The PFC MegaPAC and PFC MegaPAC-High Power units are supplied with serrated, flanged hex-nuts on all output studs. Therefore, thread locking compounds or lock washers are not required. The maximum torque recommended on flanged nuts is 45 lb-in. Never loosen the inner nut on a ConverterPAC. This nut supports the hardware inside the ConverterPAC and is factory torqued.

Avoid applications in which the unit is exposed to excessive shock or vibration levels. In such applications, a shock absorption mounting design is required.

MegaPAC Do's and Don'ts

- For units without Autosense, do not leave ConverterPAC Sense lines open. Always terminate them to their respective output locally or at the load. Use twisted pair 22-24 AWG wire. If ConverterPAC has Autosense, no local sense connection is required. See page 10 and 13 for more information on Autosense.
- If needed, use Connector Kit # 19-130040 for the PFC MegaPAC and PFC MegaPAC-High Power.
- Always fill all output slots of the MegaPAC. If a slot is not filled with a ConverterPAC, it should be filled with an airblock. Airblocks are plastic assemblies whose main function is to fill up an empty slot. Any airflow escape from an empty slot significantly degrades thermal performance, and can result in overheating and damage to the power supply.
- Always turn the power supply off, before disconnecting input or output wires.
- **NEVER** disconnect the +Out and -Out load wires while the supply is operating as disconnecting **WILL** cause damage to the power supply.
- Do not unplug ConverterPACs while input power is applied. They are not designed for hot-plug applications.
- Do not restrict airflow to the unit. The cooling fan draws air into the unit and forces it out at the output power terminals.
- For power expansion, use booster ConverterPACs. Viewing the unit from the output terminal side, always insert boosters to the right side of the driver.
- Do not use boosters as independent outputs. Disconnecting bus bars will damage booster ConverterPACs.
- For booster arrays, **do not remove busbars**.
- Always ensure that output hex-nuts are properly torqued before applying power to supply.
- Run the output (+/-) power cables next to each other to minimize inductance.
- Wait 5 minutes after shutting off power before inserting or removing ConverterPACs.
- The MegaPACs does not have user serviceable components. They must be returned to the factory for repairs. Contact Customer Service for a RMA number before returning the unit. Do not attempt to repair or modify the power supply in any manner other than the exchange of ConverterPACs as described in this Design Guide.
- Insert proper fault protection at power supply input terminals (i.e., a fuse).
- Use proper size wires to avoid overheating and excessive voltage drop.
- Never loosen the inner nut on a ConverterPAC.
- Verify output nuts are tight before powering up.
- FinPACs require 2 slots each because of the larger heatsink attached to dissipate the extra heat generated by the higher power Maxi modules. Refer to page 7 for more information on which ConverterPACs can be used.
- FinPAC ConverterPACs cannot be used in older PFC MegaPAC chassis. Contact Westcor for more information.

Technical Description

The PFC MegaPAC and PFC MegaPAC-High Power chassis consists of an off-line single phase, power-factor-corrected front end, EMI filter, cooling fan, customer interface and associated housekeeping circuits. Input AC mains voltage (L1, L2 and GND) is applied to a terminal block. The input current is passed through an EMI filter designed to meet conducted noise limit "B" specifications of FCC Part 15, VDE 0871, and EN55022 class A. At start-up, inrush current is limited by a PTC thermistor. The PTC is shunted out shortly after initial power-up by a DC bus voltage Sense circuit driving a relay. After rectification, the input voltage is put through a boost converter that keeps the AC input current sinusoidal and synchronized with the AC input voltage (in compliance with EN61000). The boost converter delivers regulated high voltage DC to the hold-up capacitors and backplane. The backplane supplies power to a variety of ConverterPAC assemblies that provide the desired regulated outputs.

Voltage conversion in the output assemblies is achieved by Vicor's family of Zero-Current-Switching (ZCS) DC to DC converters. These are forward converters in which the main switching element switches at zero current. This patented topology has a number of unique attributes: low switching losses; high frequency operation resulting in reduced size for magnetics and capacitors; excellent line and load regulation; wide adjustment range for output; low EMI/RFI emissions and high efficiencies.

At initial power-up the PFC MegaPAC and PFC MegaPAC-High Power outputs are disabled to limit the inrush current and to allow the DC bus potential to settle out to the correct operating level. A low-power flyback converter operating with PWM current-mode control converts the high voltage DC bus into regulated low voltage to power the internal housekeeping circuits and DC cooling fan. The internal housekeeping Vcc comes up within 2 s after the application of input power. Once the high voltage bus is within its limits, the AC OK signal asserts to a TTL "1" indicating the input power is OK, and enables the power outputs. An auxiliary Vcc output of 5 Vdc sourcing up to 0.3A is provided for peripheral use.

An output Enable/Disable function is provided by using an optocoupler to control the Gate In pins of the ConverterPAC assemblies. If the Enable/Disable control pin is pulled low, the optocoupler turns on, pulling the Gate In pin low and disabling the ConverterPAC output. The nominal delay for an output to come up when measured from release of the Enable/Disable pin is 10-15 ms. The General Shutdown function controls all outputs simultaneously and works in a similar manner.

The ride-through (holdup) time is the amount of time the load can be supported before loss of output regulation after the loss of input power. Detecting the loss of input power takes a finite time period after which the AC Power OK signal goes from a TTL "1" to "0." This signal is available for use within 1.2 seconds after initial power-up and can be used to indicate an impending loss of power. At least 3 ms of warning time is given. Following the loss of input power, the outputs are disabled when the bus voltage drops below its operating threshold.

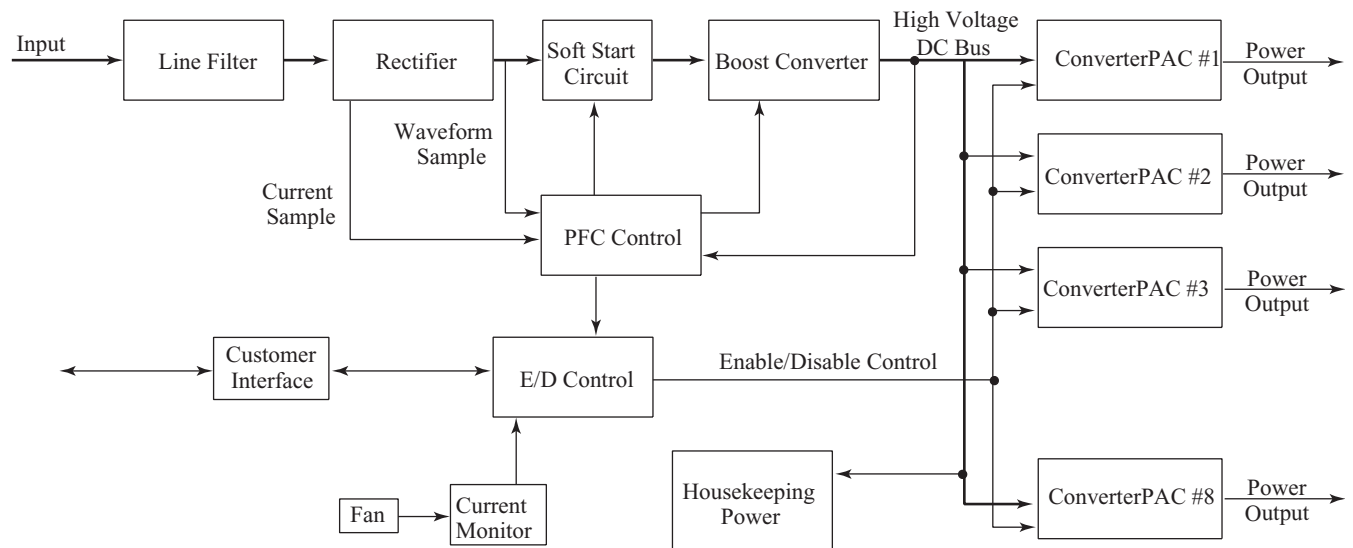

Figure 1. PFC MegaPAC and PFC MegaPAC-High Power Architecture

Configuring and Reconfiguring MegaPACs

Most ConverterPACs of the same length can be inserted into any available slot of a MegaPAC chassis. They can also be easily added, replaced, or moved by sliding the assemblies in or out of a MegaPAC chassis. (Currently, two exceptions are the FinPACs which can only be used in the PFC MegaPAC-High Power and the UniPACs which can only be used in the 4kW MegaPAC.) For outputs greater than 200 Watts, a driver ModuPAC and one or more booster ConverterPACs will be used. For outputs greater than 600 Watts, a driver FinPAC and one or more booster ConverterPACs will be used. Arrays of drivers and boosters should be configured so all boosters are placed in the slots to the immediate right of the driver when looking at the output end of the MegaPAC.

Prior to removing or installing ConverterPACs, you must remove power from the MegaPAC and wait 5 minutes. Failure to do so can result in personal injury or damage to the supply.

Take standard ESD precautions when handling ConverterPACs.

Removing ConverterPACs

ConverterPACs can be removed by loosening the captive screw at the base. Once this screw has been loosened, the ConverterPAC will slide out of the chassis. **Once a ConverterPAC has been removed, the empty slot MUST be filled with either another ConverterPAC or an airblock.** If the slot is left empty, it will provide an airflow escape and cause failure to the power supply.

Installing ConverterPACs as Drivers

ConverterPACs can be installed in empty slots by simply sliding in the new ConverterPAC and securing the screw at the base. Power and interface connections can be made after the ConverterPAC has been installed.

Installing Booster ConverterPACs to Increase Output Power

ConverterPACs can be paralleled for more power. Additional power to an output is obtained by connecting one or more boosters in parallel with a single driver. The driver can be placed in any open slot. All boosters should be inserted in the slots to the immediate right of the driver as viewed from the output end of the MegaPAC. Figure 2 shows a driver placed in slots #1 and 3 boosters placed in slots # 2 to 4. After inserting the driver and boosters, they are paralleled using bus bars across the positive and negative output studs. Drivers should not be paralleled with each other. Bus bars between a driver and booster (s) should never be disconnected. For help in identifying boosters and drivers, refer to the Part Numbering section on page 8. Please note that total output voltage should not exceed the converter baseplate-output isolation rating of 400V. For detailed guideline on how outputs should be placed in series, please refer to the Applications note (Creating high voltage outputs) available on the website at www.vicorpower.com.

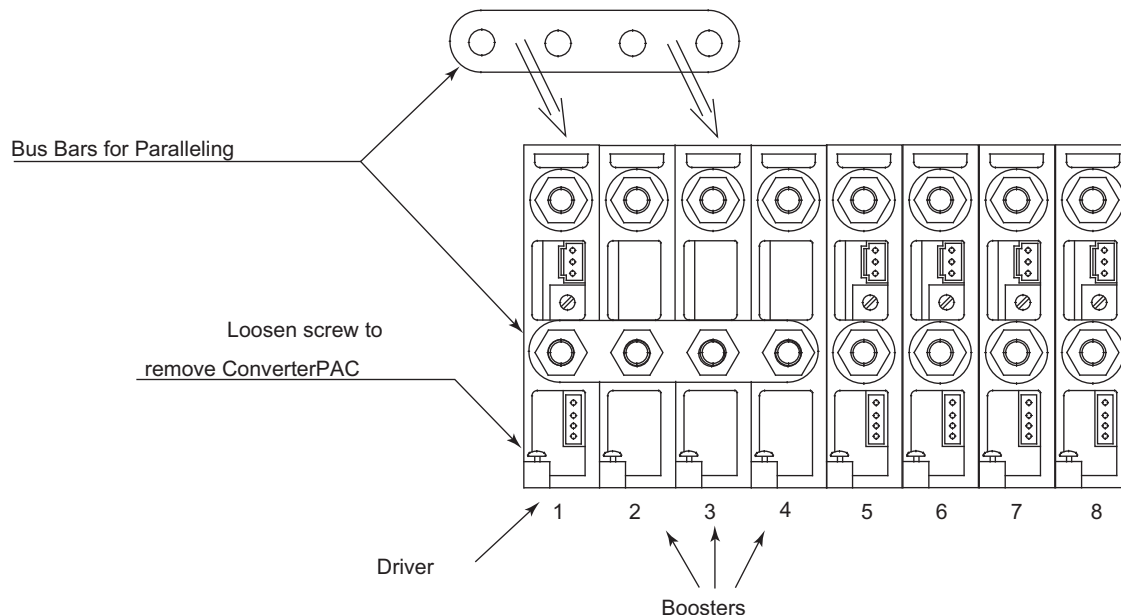
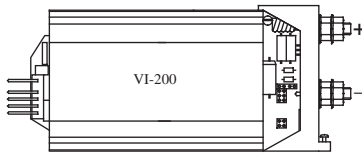

Figure 2. Paralleling ConverterPACs

ConverterPAC Functional Description (See ConverterPAC Datasheet and/or Design Guide for complete information on all ConverterPACs.)

ConverterPACs are the family of slide-in output assemblies used in MegaPAC power supplies. Most ConverterPACs of the same length are interchangeable within a MegaPAC and between different AC input MegaPAC chassis (Exceptions are the FinPAC and UniPAC). They can be added, moved, or changed as necessary. The following ConverterPACs can be used in the PFC MegaPAC and/or PFC MegaPAC-High Power. New output studs were installed on ConverterPACs and are 1/8th" longer. Refer to pages 12 and 19 for more information.

ModuPAC



ModuPAC

The ModuPAC output assembly consists of a **VI-200** DC to DC converter that converts the high voltage bus to the desired regulated output voltage. Each ModuPAC can provide up to 200 Watts of power. Multiple ModuPACs can be paralleled in a driver-booster configuration to provide more power. ModuPACs are fused with a PC-Tron, DC-rated, fast-acting fuse. A passive LC filter is used to reduce output ripple/noise down to 1% typical, and 2% maximum peak-to-peak from 10% to 100% of rated load. An optional DC Power Good signal, or output voltage Trim potentiometer can be specified. The ModuPAC contains overvoltage protection (OVP), overcurrent protection (OCP), and overtemperature limiting (OTL). The OCP has automatic recovery when the overcurrent condition is removed. The OVP and OTL are latching functions and require recycling of the AC input power to restart.

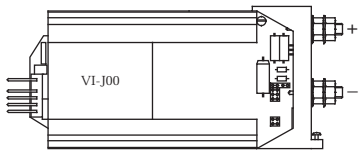

JuniorPAC

JuniorPAC

The JuniorPAC consists of a **VI-J00** DC to DC converter that converts the high voltage bus to the desired regulated output voltage. JuniorPACs can provide up to 100 Watts of output power and are fused with a single PC-Tron, DC-rated, fast-acting fuse. A passive LC filter is used to reduce output ripple/noise down to 1% typical, and 2% maximum peak-to-peak from 10% to 100% of rated load. An **optional** DC Power Good signal or output voltage Trim potentiometer can be specified. The JuniorPAC contains output overcurrent protection, which recovers automatically when the overcurrent condition is removed. **Overvoltage protection and overtemperature limiting are not available.**

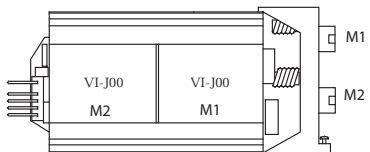

DualPAC

DualPAC

This output assembly consists of two **VI-J00** DC to DC converters that convert the high voltage bus to the desired regulated output voltages as noted above. For detailed pin out description, refer to pg 9.

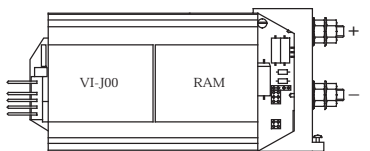

RamPAC

RAMPAC

This output assembly consists of a **VI-J00** DC to DC converter **with a Ripple Attenuator Module (RAM)** and is designed for applications requiring low output ripple/noise. The RAMPAC can attenuate the ripple/noise down to 10 mV peak-to-peak over a 20 MHz bandwidth from 10% to 100% of rated load of the converter. Outputs from 5V to 50V are available.

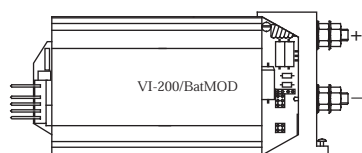

BatPAC

BatPAC

The BatPAC output assembly consists of a **VI-200** BatMod current source that converts the high voltage bus to the desired regulated output voltage. The converter is fused with a PC-Tron, DC-rated, fast-acting fuse. The BatPAC is a 200 Watts programmable current source that can be configured as a battery charger. Maximum current and voltage settings are controlled using potentiometers that come as a standard feature, or through Trim pin access as an option. BatPACs are available for 12V, 24V and 48V battery systems.

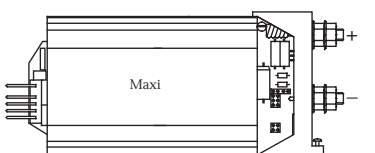

FinPAC

FINPAC

The FinPAC output assembly consists of a **Maxi** DC to DC converter that converts the unregulated high voltage bus to the desired regulated output voltage. Each Maxi module can provide up to 600 Watts of output power. Each FinPAC occupies 2 slots because it has an extra large heatsink attached to dissipate the heat generated by this more powerful Maxi converter. Currently, the FinPAC is **ONLY** used in the PFC MegaPAC-High Power. It cannot be used in any other member of the MegaPAC Family. Contact Westcor for future updates.

LIST OF CONVERTERPACS USED IN THE PFC MEGAPAC AND PFC MEGAPAC-HIGH POWER AND THEIR FEATURES

<u>ConverterPAC</u>	<u>OVP</u>	<u>OCP</u>	<u>OTL</u>	<u>RS/AS</u>	<u>LS/AS</u>	<u>PG</u>	<u>TrimPot</u>
ModuPAC	Std	Std	Std	AS*	AS*	Opt	Opt
JuniorPAC	N/A	Std	N/A	AS*	AS*	Opt	Opt
DualPAC	N/A	Std	N/A	AS*	AS*	N/A	Opt
RAMPAC	N/A	Std	N/A	AS*	AS*	Opt	Opt
BatPAC	N/A	Std	N/A	N/A	N/A	N/A	Std
FinPAC**	Std	Std	N/A	AS*	AS*	Opt	Opt

OVP	Overvoltage Protection (latching)	RS	Remote Sense
OCP	Overcurrent Protection (auto-recovery)	LS	Local Sense
OTL	Overtemperature Limiting (latching)	AS	Autosense
PG	Power Good (DC OK TTL Signal)		

* See page 10 and 13 for more information on Autosense.

** All the above mentioned ConverterPACs can be used in both the PFC MegaPAC and PFC MegaPAC-High Power except the FinPAC which currently can only be used in the PFC MegaPAC-High Power. (The UniPAC - not listed above - cannot be used either in the PFC MegaPAC or the PFC MegaPAC-High Power. Currently, the UniPAC is only used in the 4kW MegaPAC.)

Note: All ConverterPACs mentioned above can be paralleled EXCEPT the DualPAC, JuniorPAC and RamPAC.

Part Numbering

PFC MegaPAC **MPxA-7xBxxxx**
 eg. **MP5-782566**

PFC MegaPAC-High Power **MXxA-7xBxxxx**
 eg. **MX4-741437**

MP PFC MegaPAC Prefix

MX PFC MegaPAC-High Power Prefix.
 X represents the use of a PFC chassis that can use Maxi

xA Number of outputs
7 Power Factor Corrected chassis

xB Number of modules
xxxx Assigned by Westcor

ConverterPAC **XxDV/xEAXF**
 eg. **M15V/10A**
 M15V/10ADFI
 D15V/6.7A-12V/8.3AT

X ConverterPAC type (For RoHS, add G to current prefix)
 M - ModuPAC (RoHS =GM) R - RAMPAC (RoHS = GR)
 D - DualPAC (RoHS = GD) B - BatPAC (RoHS = GB)
 J - JuniorPAC (RoHS = GJ) PZ - FinPAC (RoHS = GPZ)
xD Voltage out
xE Current out (rounded to 1 decimal point)
xF Options (See below*). Can be multiple options.

*ConverterPAC Options

B Booster module	M Military Grade module
D DC OK or Power Good ¹	R RAM external ³
F Full 50-110% output adjustment ²	S Trimpot removed for external BatPAC adjustment
F1 50-107.5% output adjustment	T 90-110% output adjustment ⁴
F2 50-105% output adjustment	T1 90-107.5% output adjustment
F3 50-102.5% output adjustment	T2 90-105% output adjustment
F4 50-100% output adjustment	T3 90-102.5% output adjustment
F5 60-110% output adjustment	T4 90-100% output adjustment
F6 70-110% output adjustment	T5 98-105% output adjustment
F7 80-110% output adjustment	T6 100-110% output adjustment
F8 90-110% output adjustment	V1 "VXI" low noise (150 mV or less) 15V < Vout ≤ 24V outputs ⁵
F9 100-110% output adjustment	V2 "VXI" low noise (50 mV or less) Vout ≤ 15 Vdc
I Industrial Grade module	V3 "VXI" low noise (1% ripple or less) Vout > 24V
K Custom SRF module used	
P Preload	

¹ **D option:** Optional for all ConverterPACs EXCEPT the DualPAC, BatPAC and RamPAC

² **F options:** Optional for all ConverterPACs EXCEPT the BatPAC and DualQPAC

³ **Ram:** When using an external RAM, components such as autosense resistors and local sense jumpers must be removed before turning on the supply. In addition, in order to insure proper operation, sense pins must be connected either locally or remotely after the RAM's output. For further information, contact Applications Engineering.

⁴ **T options:** Optional for all ConverterPACs EXCEPT the BatPAC and DualQPAC

⁵ **V options:** Optional ONLY on the ModuPAC, DualPAC and JuniorPAC. N/A on all other ConverterPACs. **Requires 15% minimum load**

ConverterPAC Output and Connector Pin Identification for the PFC MegaPAC and PFC MegaPAC-High Power

ModuPAC JuniorPAC RAMPAC

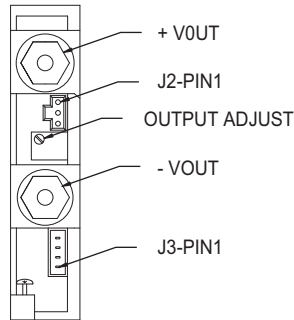

J2 (REMOTE SENSE)

1	TRIM PIN ACCESS
2	+ SENSE
3	- SENSE

J3 DC OK (POWER GOOD)

4	Vcc IN
3	POWER GOOD
2	POWER GOOD INVERTED
1	SIGNAL GROUND

MATING HDWR:

HOUSING- MOLEX P/N: 50-57-9403
 TERMINALS- MOLEX P/N: 16-02-0103
 CRIMP TOOL MOLEX P/N: 11-01-0208

MATING HDWR:

HOUSING- MOLEX P/N: 39-01-0043
 TERMINALS- MOLEX P/N: 30-00-0031
 CRIMP TOOL MOLEX P/N: 57005-5000

DualPAC

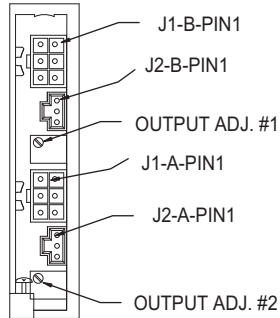

J1 (OUTPUT CONNECTORS)

4	1	1 AND 4 +V OUT
5	2	2 AND 5 -V OUT
6	3	3 +R/SENSE 6 -R/SENSE

J2 (REMOTE SENSE)

1	TRIM PIN ACCESS
2	+ SENSE
3	- SENSE

MATING HDWR:

HOUSING- MOLEX P/N: 39-01-2060
 TERMINALS- MOLEX P/N: 39-00-0039
 CRIMP TOOL MOLEX P/N: 11-01-0197

MATING HDWR:

HOUSING- MOLEX P/N: 50-57-9403
 TERMINALS- MOLEX P/N: 16-02-0103
 CRIMP TOOL MOLEX P/N: 11-01-0208

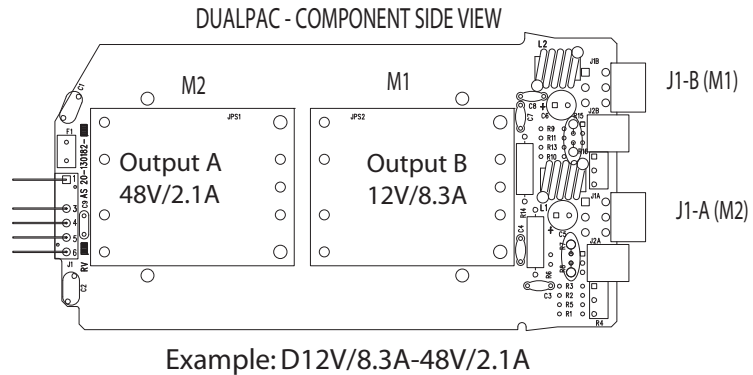

Note:

1. All ConverterPACs except the FinPAC occupy one slot. The FinPAC occupies two slots.
2. New output studs were installed on the ConverterPACs and are 1/8th inch longer. Refer to pages 12 and 19 for more information.

ConverterPAC Output and Connector Pin Identification for the PFC MegaPAC and PFC MegaPAC-High Power

BatPAC

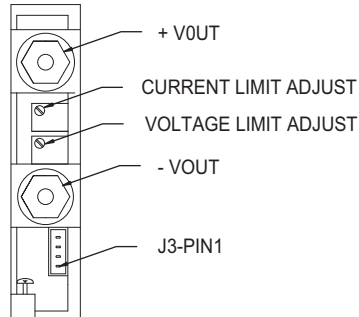

J2 (BATPAC REMOTE INTERFACE)

4	CURRENT LIMIT ADJUST
3	VOLTAGE LIMIT ADJUST
2	CURRENT MONITOR
1	-VOUT

MATING HDWR:
 HOUSING- MOLEX P/N: 39-01-0043
 TERMINALS- MOLEX P/N: 30-00-0031
 CRIMP TOOL MOLEX P/N: 57005-5000

FinPAC

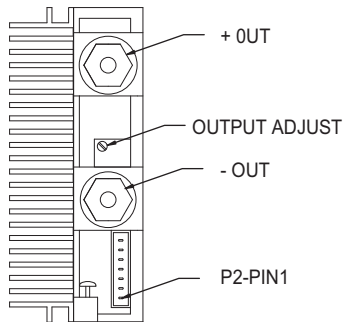

P2 REMOTE SENSE TRIM/SC & POWER GOOD

7	+SENSE
6	-SENSE
5	TRIM
4	Vcc IN
3	POWER GOOD
2	POWER GOOD INVERTED
1	SIGNAL GROUND

MATING HDWR:
 HOUSING- MOLEX P/N: 39-01-0073
 TERMINALS- MOLEX P/N: 39-00-0031
 CRIMP TOOL MOLEX P/N: 57005-5000

Note:

1. All ConverterPACs except the FinPAC occupy one slot. The FinPAC occupies two slots.
2. New output studs were installed on the ConverterPACs and are 1/8th inch longer. Refer to pages 12 and 19 for more information.

PFC MegaPAC and PFC MegaPAC-High Power “Quick Install”

Instructions (For Mechanical Drawing, see page 12)

Mounting the PFC MegaPAC and PFC MegaPAC-High Power

- * Mount the power supply on any of its four sides.
- * Use #8-32 or 4mm mounting screws. Do not exceed a maximum penetration of 0.15" (3,8mm). The maximum allowable torque is 5.5 lb-in.
- * Maintain 2" (5,1cm) clearance at either end for airflow.

Input Connections

Input Power J9

- * Apply input AC power to terminal block J9 using a pressure screw terminal.
- * Strip length of AC power conductors to be 0.35 inches.
- * Maximum torque is 4.4 lb-in.
- * Place a fuse or circuit breaker in the input line for safety reasons.
- * Use a maximum wire size of 14 AWG with soldered terminals.
- * The connector manufacturer recommends the wires not be tinned. A ferrule (Phoenix P/N 32-00-58-0, purchased from other sources) can be used to prevent fraying.

Input Panel Connectors

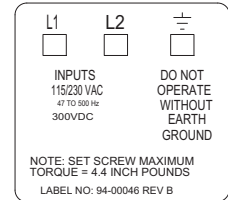

Output Connections

Power Connections

Installing ring lugs and/or bus bars on output studs:

- * The upper stud is Positive and the lower stud is the Return.
- * Newer outputs studs are 1/8th inch longer. See pgs. 12 and 19 for more information.
- * Remove nut.
- * Place ring lug over output stud.
- * Replace and tighten outer nut to a maximum torque of **45 lb-in. Do Not Over-Tighten Nuts.**
- * Verify all output nuts are properly installed before turning on supply.

Installing power connectors on DualPACs (J1A and J1B):

- * Use Molex mating receptacle #39-01-2060 with #39-00-0039 terminals provided.
- * Pins 1 and 4 are Positive, while pins 2 and 5 are the Return.
- * Attach terminals to 18-24 AWG stranded wire using Molex tool #11-01-0197.

Single Output ModuPAC

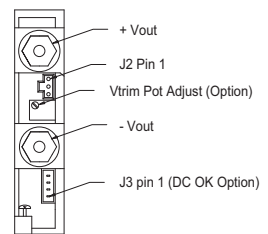

DualPAC Output Connector

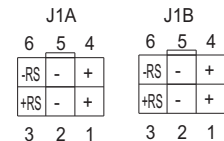

Sense Connections

Note: Newer power supplies have the Autosense feature. For these units, if Remote Sense connections are not made or needed, no Local Sense selection is necessary - simply connect the output to the load and the unit will automatically operate in Local Sense. If Remote Sense connections are made, the unit will operate in a Remote Sense mode. Remote Sense terminals should be terminated to their respective output i.e. - RS to - Output and + RS to + Output. See page 13 for more information on Autosense. **For units without Autosense, sense connections must ALWAYS be made. Not connecting sense lines to their respective output can cause failure to the unit.**

Sense Connector J2 (and P2 for the FinPAC):

- * Sense connections do not have to be made if the Local Sense option was ordered or if Autosense is present (see above note on Autosense.)
- * Use Molex mating receptacle #50-57-9403 with #16-02-0103 terminals provided.
- * J2-2 is the +Sense and J2-3 is the -Sense.
- * Attach terminals to 22-24 AWG twisted pair wire using Molex tool #11-01-0208.
- * Attach opposite ends of Sense lines to point where regulation is desired.
- * **Verify that Sense lines are not cross-connected before applying input power.**
- * For the FinPAC, P2-7 is the + Sense and P2-6 is the -Sense.
- * Use Molex mating receptacle #39-01-0073 with #39-00-0031 terminals provided
- * Attach terminals to 22-28 AWG stranded wire using Molex tool #57005-5000.

J2 Sense Connector

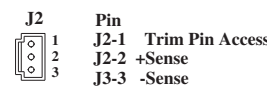

P2 Sense Connector

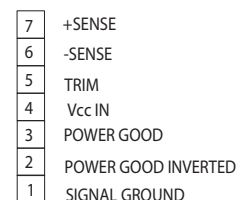

Sense Connections on DualPACs:

- * Sense connections do not have to be made either if the Local Sense option has been ordered or Autosense is present (refer to note on Autosense).
- * Sense connections are available on the J2 connector (P2 for the FinPAC) or the J1A and J1B connectors.
- * If using J2 or P2 connector, see instructions on page 10.
- * On J1A and J1B, Pin 3 is the +Sense and Pin 6 is the -Sense.
- * Use Molex mating receptacle #39-01-2060 with #39-00-0039 terminals provided.
- * Attach terminals to 18-24 AWG twisted pair wire using Molex tool #11-01-0197.
- * **Verify that Sense lines are not cross-connected before applying input power.**

DualPAC Output Connector

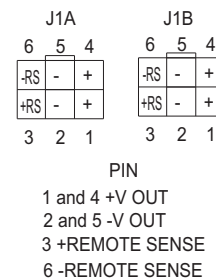

Trim Pin Connection J2 (and P2 for FinPAC)

- * The Trim J2 connection should only be made if the Trim option has not been installed. (A “T” or an “F” in the ConverterPAC part number means the Trim option is installed; e.g. M5V/40AT.)
- * Use Molex mating receptacle #50-57-9403 with #16-02-0103 terminals provided.
- * Attach terminals to 22-24 AWG stranded wire using Molex tool #11-01-0208.
- * J2-1 provides Trim access.
- * For the FinPAC, refer to P2 Connector. P2-5 provides Trim Access.
- * Use Molex mating receptacle #39-01-0073 with #39-00-0031 terminals provided.
- * Attach terminals to 22-28 AWG stranded wire using Molex tool #57005-5000.

J2 Trim Pin Connector

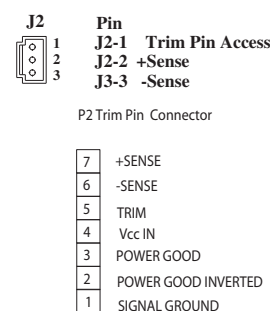

DC OK (Power Good) Connection J3 (and P2 for FinPAC)

- * DC OK is only available as an option and is not always present.
- * J3-4 is Vcc In, J3-3 is Power Good, J3-2 is Power Good inverted, and J3-1 is Signal Ground.
- * Use Molex mating receptacle #39-01-0043 with #39-00-0031 terminals provided.
- * Attach terminals to 22-28 AWG stranded wire using Molex tool #57005-5000.
- * For the FinPAC, refer to the P2 Connector. P2-3 is Power Good.
- * Use Molex mating receptacle #39-01-0073 with #39-00-0031 terminals provided.
- * Attach terminals to 22-28 AWG stranded wire using Molex tool #57005-5000.

DC OK (Power Good)

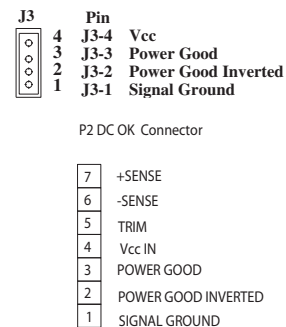

Interface Connections J10

- * Use Molex mating receptacle #39-01-2120 with #39-00-0039 terminals provided.
- * J10-1 to 8 are Enable/Disable for slots 1-8.
- * J10-9 is Vcc, J10-10 is Signal Ground, J10-11 is AC Power OK, and J10-12 is General Shutdown.
- * Attach terminals to 18-24 AWG stranded wire using Molex tool #11-01-0197.

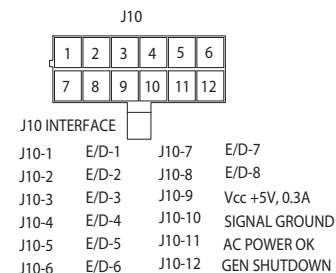

PFC MegaPAC and PFC MegaPAC-High Power Mechanical Drawing

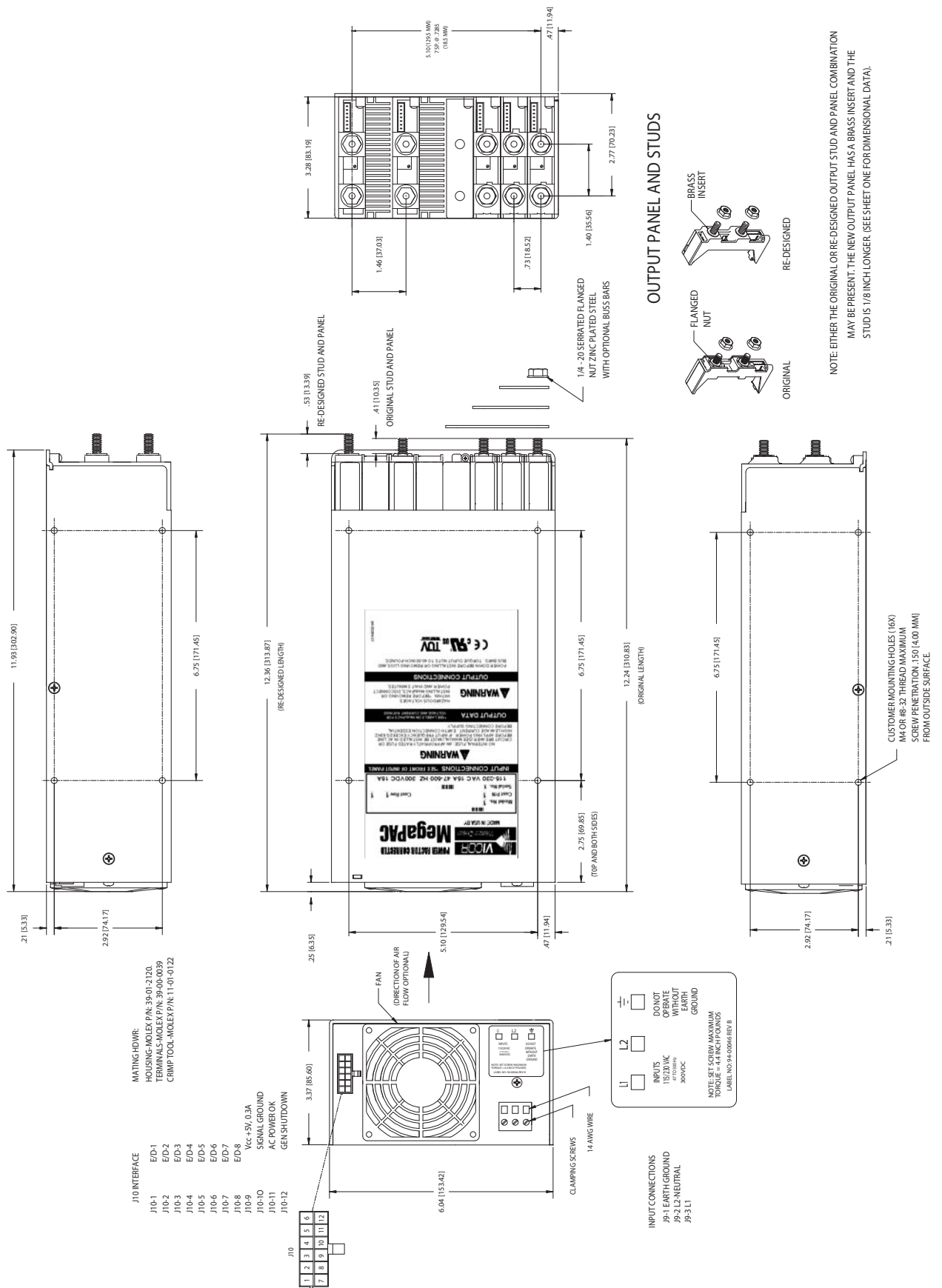

Interface Connections

Chassis Input Power Terminals (J9)

Input AC power is applied to terminal block J9 using a pressure screw terminal that accepts a maximum wire size of 14 AWG. The insulation should be stripped .35 inches and the maximum torque applied to the screws should not exceed 4.4 lb-in. The connector manufacturer recommends the wires not be tinned. A ferrule (Phoenix P/N 32-00-58-0, purchased from other sources) can be used to prevent fraying. J9-1 (GND) is Earth Ground for safety; J9-2 (L2) and J9-3 (L1) are the other Hot connections. For Input DC power, L2 is (+) and L1 is (-).

A fault clearing device, such as a fuse or circuit breaker with a maximum 15A rating at the power supply input is required for safety agency compliance. It should be sized to handle the start-up inrush current of 25A pk at 115 Vrms and 230 Vrms.

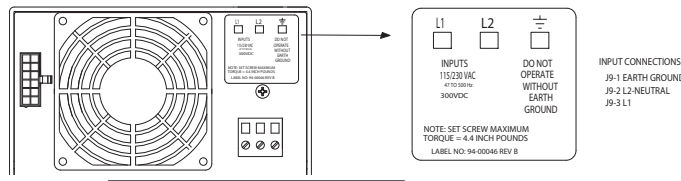

Figure 3. Input Panel Connectors

Output Power Connections (+P, -P for Single Output, or J1A/J1B for Dual Outputs)

For single output ConverterPACs, these terminals are two 1/4-20 plated steel studs. The upper stud is positive with respect to the lower stud. For dual output ConverterPACs, there is a 6-pin Molex connector for each output. J1A pins 1 and 4 are the +Output, and J1A pins 2 and 5 are the -Output. Pins 3 and 6 are duplicates of the Remote Sense terminals present on J2A and J2B. Use appropriate wire size rated to handle the full output current, including short circuit levels. Avoid large current loops in output cables; run power and return cables next to one another to minimize inductive effects. All outputs are isolated and can provide positive or negative outputs.

Output +/-Sense Connections -J2 for Single Output, or J1A/J1B for Dual Outputs

Newer power supplies may have some outputs configured with the Autosense feature that automatically locally senses the output if remote sense is not used. To check if an output has the Autosense feature, measure the impedance from the + Out to + Sense and - Out to - Sense pins. If the impedance is 5 ohms, then the output has Autosense and does not require local sense jumpers.

If units do not have Autosense, sense connections must be made. When making sense connections, keep in mind that although all outputs are open-Sense protected, the +/-Sense terminals **MUST** be connected to their respective outputs before the PFC MegaPAC and PFC MegaPAC-High Power are powered up. Regardless of the output polarity configured, the +Sense should always connect to the +Power output. The -Sense connects to the -Power output. Sense connections are not required on booster ConverterPACs, BatPACs, or if the Local Sense option is specified. Local Sense mode means that the Remote Sense lines are not connected. Sense pins can be accessed on J1A/J1B or J2A/J2B on dual output units.

Signal Ground (J10-10)

Signal Ground (see Figure 4 and Connector Pin Identification on page 9) is an isolated ground reference for all J10 interfacing signals, and can be used for ConverterPAC output status signals such as Power Good. This is not the same as Earth Ground on input power connector J9.

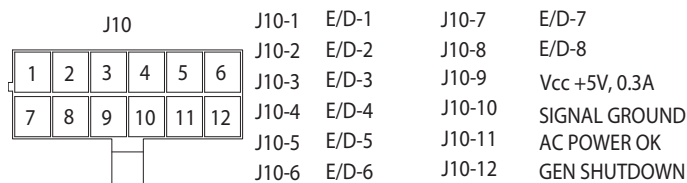

Figure 4. Interface Connector

Enable/Disable (J10-1 to J10-8)

The Enable/Disable control pins allow ConverterPAC outputs to be sequenced either on or off. J10-1 through J10-8 are the control pins for output positions 1 through 8, respectively (see Figure 5 and Connector Pin Identification on page 9). For DualPACs, both outputs are sequenced. In parallel arrays, only the driver ConverterPAC need be controlled. The Enable/Disable pins should be pulled low to less than 0.7V with respect to Signal Ground to disable the outputs. They will sink 10 mA maximum. These pins should be open circuited or allowed to exceed 4.5V when enabled. Do not apply more than 6V to these inputs at any time. If driven from an electromechanical switch or relay, a capacitor should be connected to eliminate the effects of switch bounce.

A TTL "1" applied to the base of the transistor turns output OFF. Pin 1 (or Pin 12 for GSD) is pulled Low with respect to Signal Ground.

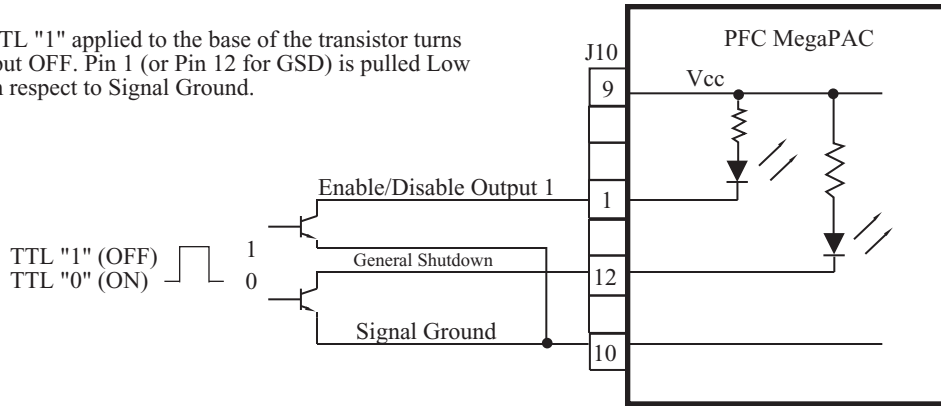

Figure 5: Enable/Disable and General Shutdown

Enable/Disable control of Maxi/Mini/Micro Module Arrays

When using the Enable/Disable function on an output that consists of two or more Maxi modules, it is necessary to connect the E/D pins of the corresponding module locations together such that both modules are commanded to turn ON or OFF simultaneously.

Example: Slots 2, 4 and 6 have been configured as a single output parallel array (see Fig. 6)

In order to disable the 48V output, E/D 2, E/D 4 and E/D 6 should be shorted together as shown in Fig.6. With E/Ds connected together, a single switch can then be used to remotely enable and disable the output.

**Note: For single output power supply configurations, the simplest method of remotely enabling and disabling the output is to use the General Shutdown (GSD) function.



Figure 6. Enable/Disable Control of Maxi Arrays

General Shutdown /GSD (J10-12)

The GSD control pin on J10-12 allows simultaneous shutdown of all ConverterPAC outputs (see Connector Pin Identification on page 9). This pin must be pulled down to less than 0.7V, and will sink 13 mA maximum to shut down all outputs. The GSD pin should be open circuited or allowed to exceed 4.5V when not in use, or when the outputs are to be enabled. Do not apply more than 6V to this input at any time. Normal open circuit voltage is 1.5 to 3V with respect to Signal Ground. If driven from an electromechanical switch or relay, a capacitor should be connected to eliminate the effects of switch bounce.

AC OK / Power Fail (J10-11)

This is an active high TTL compatible signal and provides a status indication of the AC input power (see Figure 7 and Connector Pin Identification on page 9). It is capable of sourcing 0.5mA at >3.2V and sink 16mA at < 0.5V. This signal switches to a TTL “1” when the high voltage bus exceeds low-line condition during turn-on, and switches to a TTL “0” 3 ms (minimum) before loss of output regulation due to the loss of input AC power. This signal can be used to warn external control circuits of an impending loss of power.

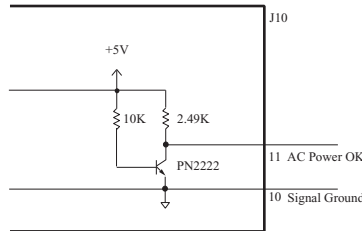

Figure 7: AC OK Power Fail

Auxiliary Vcc +5V/0.3A (J10-9)

The Vcc on J10-9 is an auxiliary 5V regulated power source (see Figure 8 and Connector Pin Identification on page 9). It is +5 Vdc +/-5% with respect to Signal Ground and can supply 300 mA maximum. It is short-circuit-proof, but if shorted all outputs will shut down through the Enable/Disable circuitry. The Auxiliary Vcc typically powers user circuitry or is used with the Power Good circuitry to provide a pull-up reference for the outputs of the DC Power Good circuit on a ConverterPAC. If used for this purpose, the Signal Ground on J10-10 must also be connected to the J3-1 Signal Ground pin of the ConverterPAC.

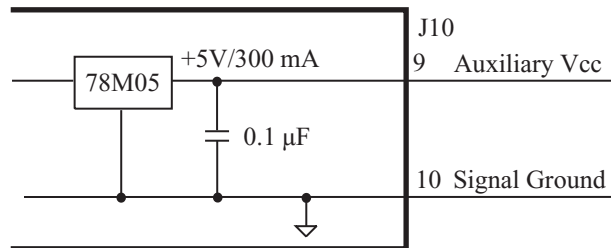

Figure 8. Auxiliary Vcc

Power Good (J3-3)

The optional Power Good signal on J3-3 is referenced to Signal Ground on J3-1, and indicates the status of the output voltage. This signal is asserted a TTL “1” when the output voltage is above 95% of nominal. It is a TTL “0” when the output voltage is below 85% of nominal. If the Trim option is also used, the Power Good trip points DO NOT track with the trimmed voltage. It is possible to trim the output below the fixed setpoints of the Power Good circuit and cause a negative Power Good signal.

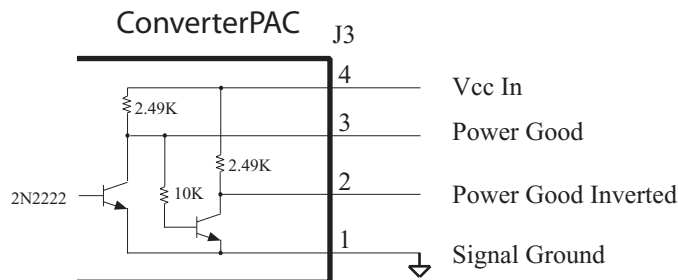

Figure 9. Power Good and Vcc

Power Good Inverted (J3-2)

This is the inverse of the Power Good signal and is referenced to Signal Ground on J3-1.

Signal Ground (J3-1)

Signal Ground on J3-1 is an isolated secondary ground reference for J3 status signals. It is used to provide a reference point for the Power Good circuitry and is not the same as Earth Ground on input power connector J9.

Vcc In (J3-4)

The Vcc In on J3-4 is an input that requires +5V either from the J10 Auxiliary Vcc, or from another source. Input current to this pin is limited by an internal resistor to 3 mA. If the J10 Auxiliary Vcc is connected to Vcc In on J3-4, then the J10 Signal Ground must be connected to Signal Ground on J3-1.

+Sense/-Sense - J2-2 and J2-3 (See page 10 and 13 for information on Autosense)

The +Sense on J2-2 should be connected to the +Power Out, and the -Sense on J2-3 to the -Power Out terminal. **Do not reverse or leave the Sense pins open.** Sense pins can be terminated locally at the output of the power supply, in which case the power supply will provide regulation at the output terminals. The voltage appearing at the load may drop slightly due to voltage drop in the power cables. If it is necessary to compensate for voltage drop along the output power cables, this termination should be made close to the output load. Compensation of up to 0.5V (0.25V per lead) can be obtained. Use twisted pair 22-24 AWG wire for this purpose.

For DualPACs, the +Sense pins are available on connectors designated as J2A-2 and J2B-2 for outputs A and B, respectively. -Sense pins are on J2A-3 and J2B-3, respectively. These pins are also duplicated on the power connectors J1A and J1B.

Reminder: Only units with Autosense will automatically operate in Local Sense mode if no sense connections are made. It will operate in remote sense mode if remote sense connections are made. Units without Autosense MUST have sense connections (Local or Remote) terminated to their respective output for the unit to operate properly.

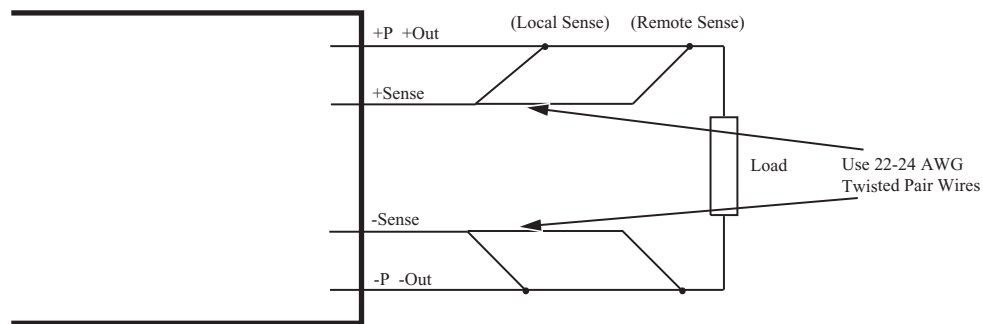

Figure 10. Sense Leads

External Trim (J2-1)

Output voltage can be trimmed using an optional factory-installed Trim potentiometer or with the Trim pin (see Figure 11). The Trim potentiometer is located on the ConverterPAC. If the Trim potentiometer has not been ordered, the Trim pin must be used. When using the Trim pin, the Trim limits are determined by the DC/DC converter used on the ConverterPAC. Maximum Trim ranges are 10% above the nominal converter voltage and 50% below the nominal converter voltage (except 10V, 12V and 15V outputs which are 10% below nominal) as measured from the output studs or output connector of the power supply.

Note: The combined effects of module trim up, remote sense and dynamic load step may cause the module to trip OVP. (See page 7 for information on restart).

The Trim pin on J2 can be used to control the output voltage. It is referenced to the -Sense pin on J2 and can be controlled by either a resistor network or an external voltage source. To increase an output voltage above its nominal, it is necessary to increase the voltage at the Trim pin above the internal reference voltage (V_{ref}). The reverse is true to decrease an output voltage.

Note: Converters are sometimes pretrimmed at the factory if a nonstandard output voltage is requested. Standard voltages include 2V, 3.3V, 5V, 10V, 12V, 15V, 24V, 28V, and 48V. If using a nonstandard voltage, or if a ConverterPAC is ordered with a Trim option, the resistor calculations will differ from those on page 17. Please consult the factory for assistance.

OUTPUT MODULE	V_{ref}	R_{TH}
VI-200/VI-J00 $\geq 3.3V$	2.50V	10.0 k Ω
VI-200/VI-J00 $< 3.3V$	0.97V	3.88k Ω
Maxi/Mini/Micro (Pre-Defined)	1.23V	1.0 k Ω

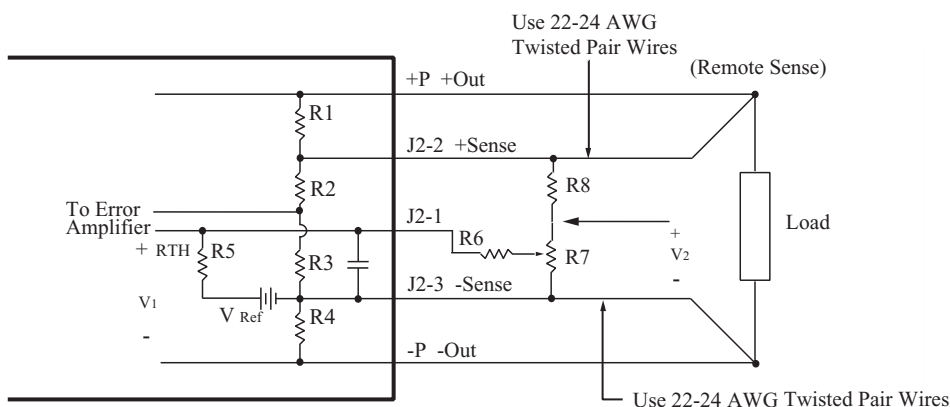

Figure 11. External Trim

Maxi/Mini/Micro (User Defined)	1.23V	Consult Factory
--------------------------------	-------	-----------------

Table 1. Module Internal Reference Voltages and Thevenin Resistances.

Example:

$\pm 10\%$ Trim adjust on a 12V nominal output.

Figure 11 shows a typical variable Trim circuit. Using a 10k trimpot (R7), the resistor values for R6 and R8 can be calculated as follows:

$$V_1 = V_{ref} + 10\% = 2.75V$$

Given: $V_{ref} = 2.5V$ (see Table 1)

$$I_{R5} = (2.75V - V_{ref})/R_{TH} = (2.75V - 2.5V)/10k\Omega = 25\mu A$$

Setting the bottom limit:

$$V_{R6} = 2.5V - 10\% = 2.25V$$

And since $I_{R5} = I_{R6} = 25\mu A$,

$$R6 = V_{R6}/I_{R6} = 2.25V/25\mu A = \underline{90k\Omega}$$

$$V_2 = V_1 + V_{R6} = 2.75V + 2.25V = 5V$$

$$I_{R7} = V_2/R7 = 5V/10k\Omega = 500\mu A$$

$$I_{R8} = I_{R7} + I_{R6} = 525\mu A$$

$$V_{R8} = (V_{nom} + 10\%) - V_2 = 13.2V - 5V = 8.2V$$

Given: $V_{nom} = 12V$

$$R8 = V_{R8}/I_{R8} = 8.2V/525\mu A = \underline{15.62k\Omega}$$

Using the above resistor combination, a 12V output can be trimmed externally up to 13.2V and down to 10.8V. For further information on external trimming, refer to Chapter 5 of the Applications Design Guide or consult the factory for assistance.

CONSULT APPLICATIONS ENGINEERING WHEN TRIMMING OUTPUTS BELOW 5V

Specifications

Input Characteristics

Input Voltage	85-264 Vac, 47-500 Hz 100-380 Vdc
Power Factor	0.99 @ 115 Vac ; 0.95 @ 230 Vac
Inrush Current	25A pk @ 115 Vrms and 230 Vrms
Ride Through Time	>20 ms at nominal line, full load
Power Fail	>3 ms warning
Conducted EMI	FCC Class A; EN55022 Class A (Certain configurations meet B. Contact Factory)
Surge Immunity	EN 61000-4-5 Installation Class 3, Performance Criteria B (Temporary loss of output power may occur which is self recoverable)
Dielectric Withstand	Primary to Chassis GND = 2,121 Vdc Primary to Secondary = 4,242 Vdc Secondary to Chassis GND = 750 Vdc

Output Characteristics

Line/Load Regulation:	Ist Gen: $\pm 0.2\%$ max. 10% to full load $\pm 0.5\%$ max. No load to 10% load	
Line Regulation*	Maxi: $\pm 0.20\%$ max. to 0.3% max LL to HL, Full Load	
Load Regulation*	Maxi: $\pm 0.1\%$ No load to full load	
VI-200/VI-J00 Setpoint Accuracy*	1% for standard voltages; 2% for special or adjustable voltages	
Maxi Setpoint Accuracy	1% for standard voltages; 2% for special, adjustable voltages and 48 Vdc outputs	
Ripple and Noise	Std. outputs: 2% or 100 mV p-p, whichever is greater, 75% min. load; VXI options: V1 = (150 mVp-p or less) 15V < Vout \leq 24V outputs V2 = (50 mVp-p or less) Vout \leq 15 Vdc V3 = (1% ripple or less) Vout > 24V (VXI options require 15% minimum load) RAMPAC: 10mVp-p or 0.15% whichever is greater	
External Output Trim Range (Using Trim/Sc pin)	10% -110% of nominal voltage Maxi modules 50% -110% of nominal voltage VI-200/VI-J00 modules 90% -110% of nominal voltage VI-200/VI-J00 modules 10-15V	
Overcurrent Trip Point	105-125% of full load capability of VI-200/VI-J00 modules 115% typical of full load capability of Maxi modules	
Overvoltage Protection	115-135% on VI-200 and Maxi modules only	
Efficiency	80% typical	
Output Power	PFC MegaPAC 1,600 W at 230 Vac 1,200 W at 115 Vac ⁺	PFC MegaPAC-High Power 2,400 W at 230 Vac 1,200 W at 115 Vac ⁺

⁺ Note; Not to exceed an input current of 15A.

Environmental Characteristics

Storage Temperature	-40°C to 85°C
Altitude	Derate 2.6% total output power for each 1,000 ft to a maximum operating altitude of 15,000 ft. Non-operating storage maximum altitude is 40K

Specifications (continued)

Operating Temperature**	-20°C to 40°C full power; -20°C to 60°C half power	
Humidity	0 to 95% non-condensing	
Safety Agency Approvals	cURus – UL 60950-1, CSA 60950-1 cTUVus – EN 60950-1, UL 60950-1, CSA 60950-1 CE Mark – Low Voltage Directive, 73/23/EEC amended by 93/68/EEC	
Product Weights (fully configured)	PFC MegaPAC 9.75 lbs (4,42 kgs)	PFC MegaPAC-High Power 10 lbs (4,54 kgs)
Warranty	2 years limited warranty. See vicorpower.com for complete warranty statement.	

* See Vicor module specifications. A preload may be necessary for modules trimmed down below 90% of normal output voltage.
 ** The maximum operating temperature is 40°C. If using a VI-200 with output voltage less than 12V and more than 150 Watts, the operating temperature decreases to 35°C. This also applies when using a FinPAC with output voltage less than 24 V and more than 500 Watts.

Output Studs

New, more robust output studs (with a 3 to 1 safety margin @ 45 in. lbs.) were installed in ConverterPACs, the slide-in assemblies used in the MegaPAC Family. These new outputs studs are 1/8" longer to allow for multiple lugs. They are fully compatible with the original flanged nut ConverterPACs for use in parallel arrays. Other advantages include:

- Inner nut (that might become loose) replaced by a brass insert
- Stronger connection to the PCB
- Improved conductivity (less voltage drop and heating)
- Both the stud and panel are less likely to break due to over torquing

Shown below are the original and re-designed studs.

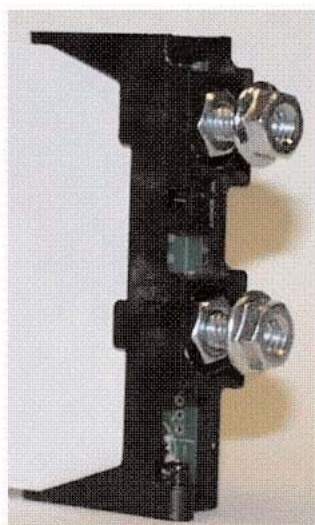

Original

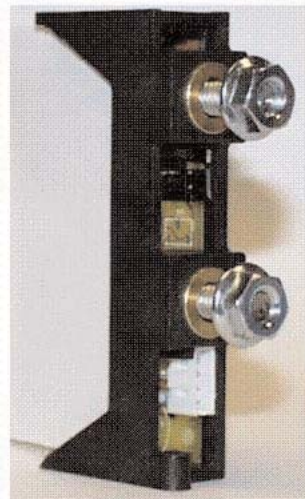

Redesigned

Refer to page 12 for dimensional data.

PFC MegaPAC Output Power Derating

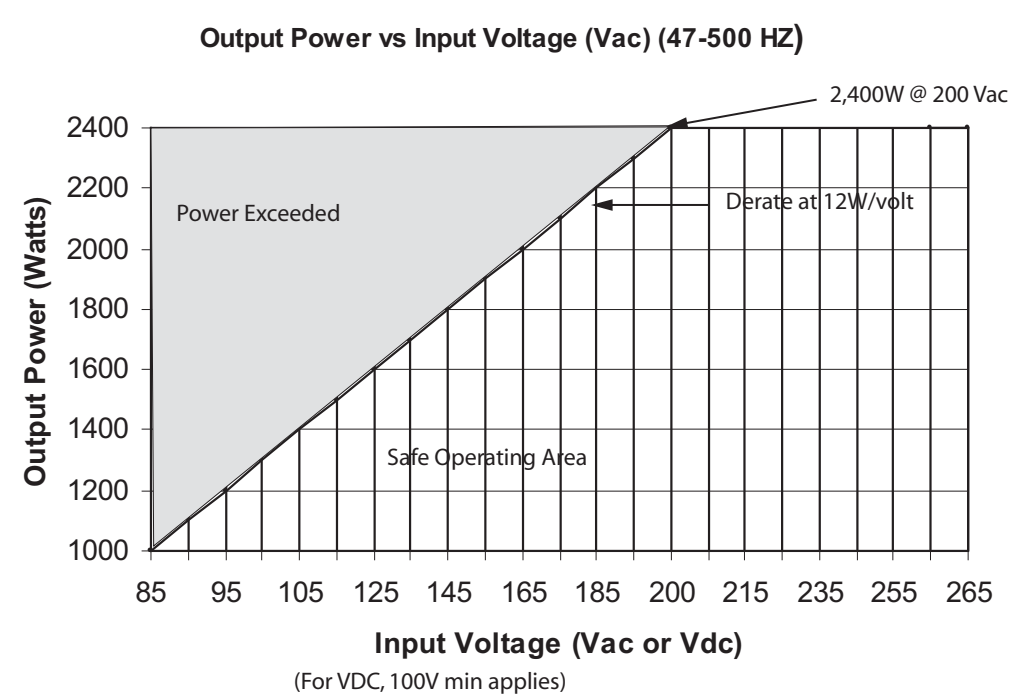

PFC MegaPAC Connector Kit (19-130040) Listing

ITEM	QTY	DESCRIPTION	VENDOR # 1	PART NO.
1	1	HOUSING 12 POS.165 CTR W/LATCH	MOLEX	39-01-2120
2	12	TERMINAL FEM CRIMP 18-24 AWG TIN	MOLEX	39-00-0039
**		CRIMP TOOL FOR ITEM 2	MOLEX	11-01-0197
3	8	HOUSING 7 POS.098 CTR L/PROFILE	MOLEX	39-01-0073
4	8	HOUSING 4 POS.098 CTR L/PROFILE	MOLEX	39-01-0043
5	94	TERM FEM CRIMP 22-18 AWG PH/BRNZ	MOLEX	39-01-0031
**		CRIMP TOOL FOR ITEMS 3 AND 4	MOLEX	00-01-0197
6	8	HOUSING 3 POS .1 CTRS W/LATCH	MOLEX	50-57-9403
7	27	TERM FEM CRIMP 22-24 AWG SEL/GLD	MOLEX	16-02-0103
**		CRIMP TOOL FOR ITEM 7	MOLEX	11-01-0118

** ITEMS FOR REF ONLY (NOT INCLUDED IN KIT)

Current Share Boards - Optional Feature

"Current sharing" also known as Load Sharing, is the ability to divide the output current evenly across all active power supplies. This greatly reduces stresses on each power supply and allows them to run cooler, resulting in higher reliability. Standard "current sharing" techniques typically utilize shunt resistors or Hall Effect devices to measure the current from each power supply. Power shunt resistors continually dissipate power and require cooling especially when dealing with high output currents of >100Amps. Hall Effect devices measure magnetic fields generated by current flowing through a conductor and, although they dissipate no power, they tend to be large and expensive.

First developed by Westcor Engineering for paralleling MegaPAC supplies, the Box-to-Box Current Share Board or CSB allows two or more Vicor power supplies to current share by utilizing the inherent voltage drop produced in the negative output return cable. This eliminates the need for additional shunt resistors or expensive Hall Effect devices and provides a simple 5 wire connection method to achieve a +/-1mV accuracy between the Negative Output power rails. This accuracy translates to a 1% current sharing if there is a total of 100mV conduction voltage drop in the negative return path.

Constructed as a current source to drive the Trim pin of a Vicor module, the design uses an accurate comparator circuit to monitor the power returns. In addition, the circuit is unidirectional and can only trim an output voltage up. The benefit is that only the supply that is supporting less current is adjusted up. This action balances the currents to the load by matching the output voltages of the supplies. In the case of one supply failing, the circuit will attempt to trim the failed supply only. This will leave the remaining functional supply alone to provide power to the load at its nominal voltage. Thus the circuit also offers simple redundancy. In addition, because CSB functions as a current source, the Trim outputs (T1 and T2) of the CSB can be placed in parallel to create a summing node. This allows current sharing between more than two supplies by paralleling the T2 output of one CSB circuit with the T1 output of the next CSB.

Please note: The CSB is not intended for use in Hotswap Applications.

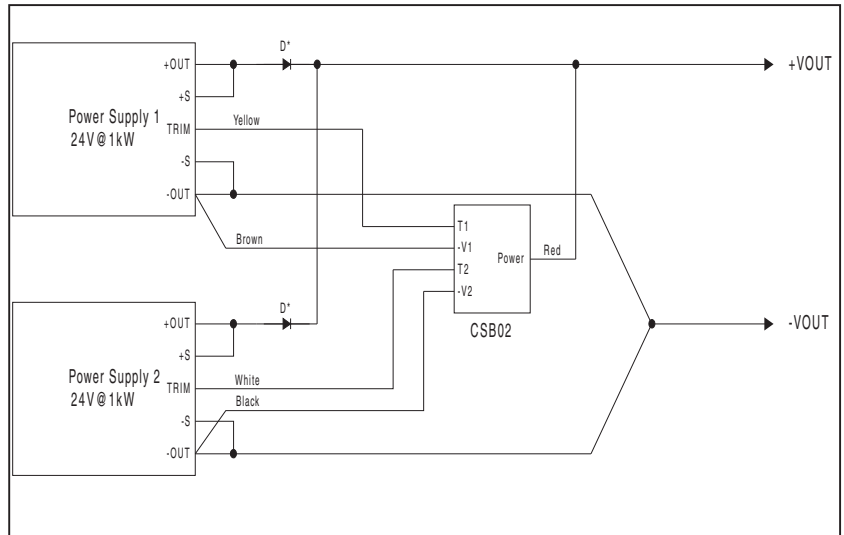

Figure 1. CSB Interconnect Example

Requirements:

1. For proper operation, the power supplies being paralleled should be enabled at the same time.

2. -Out conductors must be of equal length and wire gauge.

Separate -Out conductors must be used from each supply to the load, or the use of a "Y" connection to a common point

must be used as shown in figure 1. Each leg of the "Y" must have a minimum of a few millivolts of drop in order for proper operation. 50mV to 100mV of drop will provide from 5% to 1% accuracy.

3. -V1 and -V2 for all Box-to-Box circuits must be connected directly at the negative output power studs or terminals to achieve accurate current sharing.

4. D* can be added if redundancy is needed. If redundancy is not required, D* can be replaced with direct wire connections.

5. When using D*, the Power input should be connected on the cathode side of the paralleling diodes as shown above.

6. Terminate Sense Leads either locally or remotely as shown in figure 1.

7. For paralleling more than 2 supplies consult factory for assistance.

Current Share Boards - Optional Feature (contd)

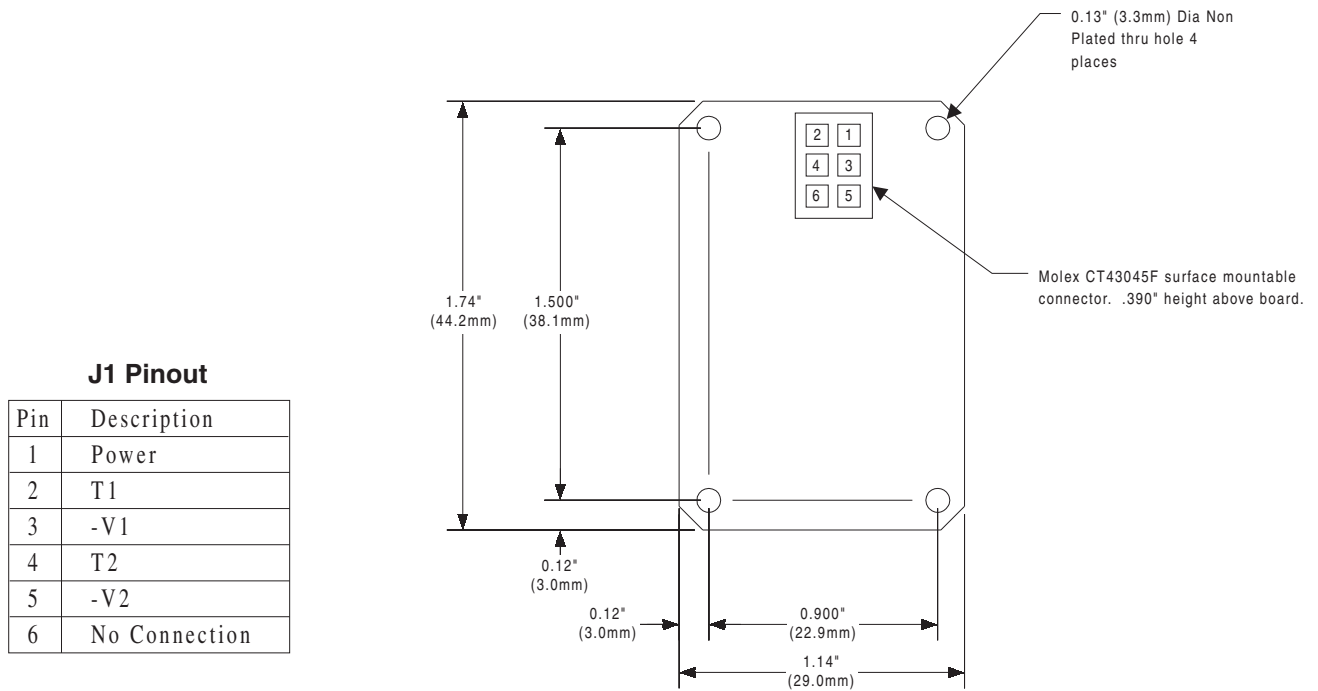

Figure 2. Mechanical Drawing

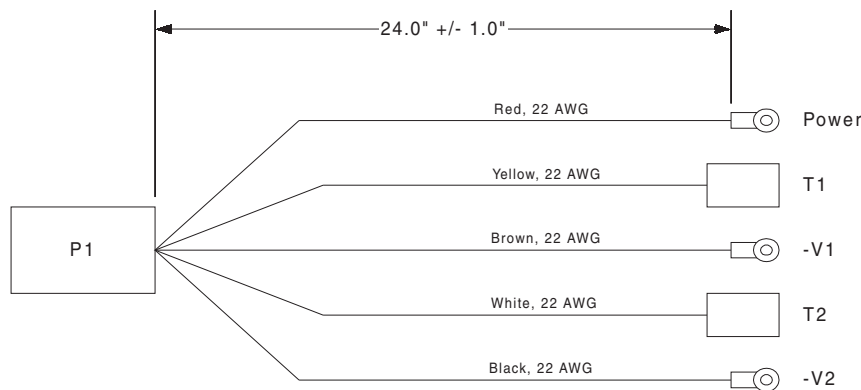

Figure 3. Cable Drawing

Specifications:

1. Power: 2-50Vdc at 5mA maximum.
2. Accuracy: +/- 1mV between -Vout connections.
3. Output current when not trimming up: +/- 1uA (VI-200/J00), +/-5uA (Maxi/Mini/Micro).
4. Use 4 non-plated through holes with standoffs for mounting.
5. CSB01 MUST be used for current sharing VI-200/VI-J00 converters (VI-200/J00).
6. CSB02 MUST be used for current sharing Maxi/Mini/Micro converters (Maxi, Mini and Micros).

*****PLEASE NOTE, THE CSB IS NOT INTENDED FOR HOTSWAP APPLICATIONS*****

Contact your Regional Applications Engineer at 1-800-927-9474 for additional information.

Low Leakage Version

If Low Leakage is required, the MegaPAC Family of Power Supplies has a model variant (must be requested). This model enables the user to meet various additional specifications. Presently, the PFC MegaPAC, Mini MegaPAC and Autoranging MegaPAC are available in Low Leakage versions. Other models can be made available. The MegaPAC Family of Power Supplies consist of:

- PFC MegaPAC
- PFC MegaPAC-High Power
- PFC MegaPAC-EL (Low Noise)
- Mini MegaPAC
- Autoranging MegaPAC
- 4kW MegaPAC
- 4kW MegaPAC-EL (Low Noise)

The advantage of the Low Leakage MegaPAC power supply is in multiple power supply systems that have one AC input. This option will lower the input leakage current for these products to 100 μ A or less. An additional external EMI filter is typically required.

How Low Leakage is obtained

Low Leakage for the MegaPAC Family of power supplies is obtained with the removal of the "Y" capacitors from within the EMI filter of the MegaPAC as well as the "Y" capacitors on the input of the ConverterPACs*. This reduces the leakage current from the AC input to AC ground (chassis) to below 100 μ A (leakage value may differ with use of Maxi modules.. Consult Factory for more information.) At the same time, since the "Y" capacitors are a vital component of the EMI filter, without them, the EMI will go up. When this happens, the unit will no longer meet Westcor's published specifications for conducted EMI. In order to reduce the EMI to within an acceptable limit, an additional external EMI filter is required. All safety agency certifications for the MegaPAC Power Supplies remain intact**. Contact Applications Engineering for more information.

* Westcor currently has the following ConverterPACs (See ConverterPAC information sheet and/or Design Guide for more information):

VI-200/VI-J00

ModuPAC (M)
JuniorPAC (J)
DualPAC (D)
RamPAC (R)
BatPAC (B)
QPAC (L)
DualQPAC (LD)
Junior QPAC (LJ)

Maxi/Mini/Micro

FinPAC (PZ)
UniPAC (XU)
QPAC (XQ)
FinQPAC (PZL)

** Please note that the MegaPACs (including Low Leakage versions) are not UL 2601 compliant.

Output Sequencing

Using the MegaPAC's standard Input Interface Connector (J10) along with the ConverterPAC's optional DC OK Option*, it is possible to implement unique output voltage power up and power down sequences. Below is an example showing how this may be done.

* DC OK Option is not available for VI-200/VI-J00 dual output DualPACs

Requirement: 5V must start before the 3.3V output. If the 5V output is lost, the 3.3V output must turn off.

The first step in meeting this requirement is to configure the 5V ModuPAC with the DC OK Option, which is indicated by a "D" designator in the ModuPAC's part number, located on the top surface of each ModuPAC above the +Vout. Any ModuPAC that has the DC OK option will also have the 4 pin J3 DC OK connector installed. To order a ModuPAC with the DC OK option, please contact Westcor's customer service department for assistance. The DC OK option monitors the output voltage of a given ConverterPAC and provides a TTL logic signal depending on its output voltage.

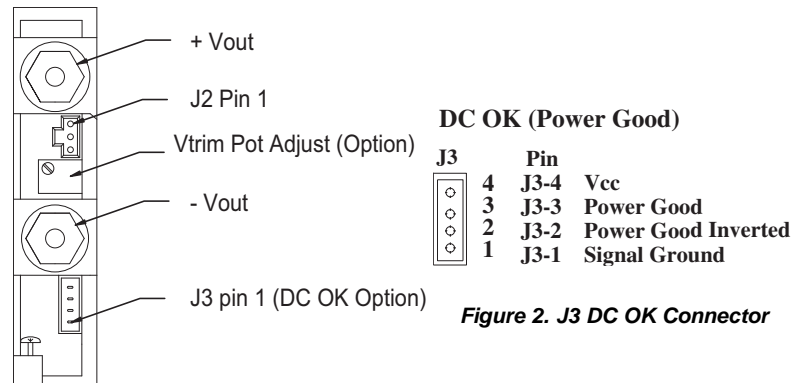

Figure 1. ModuPAC Pinout

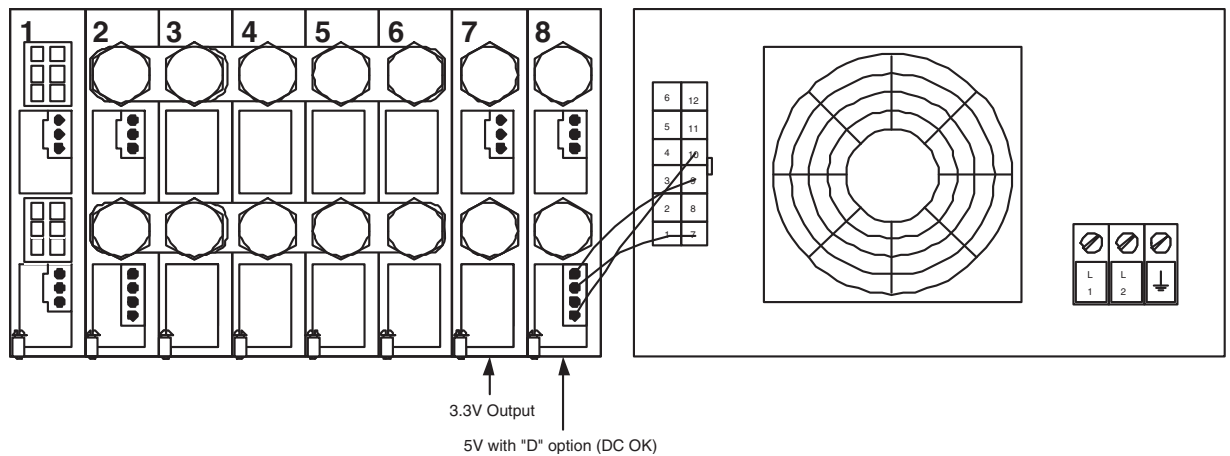

Figure 3. Output Sequencing Wire Interconnect

Figure 3 shows the correct wiring connections between the Power Good Connector (J3) of a 5V ModuPAC and the Input Interface Connector (J10) of a typical PFC MegaPAC configuration. In this example, the 3.3V ModuPAC is located in the slot #7 and the 5V ModuPAC (with the DC OK option) is located in slot #8. In order for the Power Good option to properly function, it requires a 5V source to provide the necessary Vcc pull up. This 5V source is conveniently available using the +5V aux source from the Input Interface Connector (J10-9 and J10-10). With a Vcc voltage properly applied to the 5V ModuPAC's Power Good Connector (J3-1 and J3-4), the Power Good signal (J3-3) can now be connected to the Enable/Disable control pin for slot #7 (J10-7). The 5V ModuPAC's Power Good signal will remain low until its output has reached approximately 95% of its nominal output voltage. This will keep the 3.3V output in disabled mode, allowing the 5V output to reach regulation first. In addition, should the 5V output drop below 85% the Power Good signal will drop low and disable the 3.3V output. Figure 4 and 5 show the startup and shutdown waveforms for the circuit shown in Figure 3.

Output Sequencing (contd)

- Channel #1: 5V Output
- Channel #2: 3.3V Output
- Channel #3: 5V DC OK signal

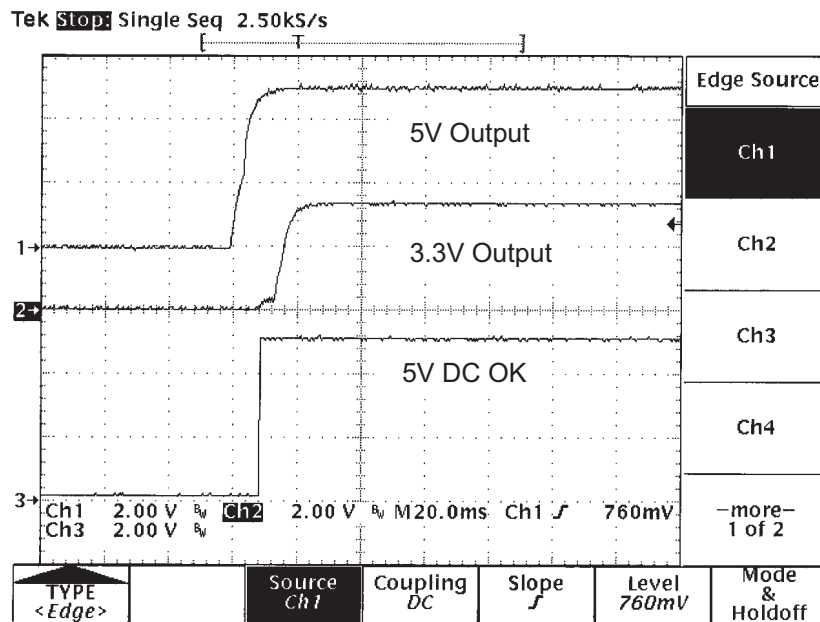

Figure 4. Startup Waveforms

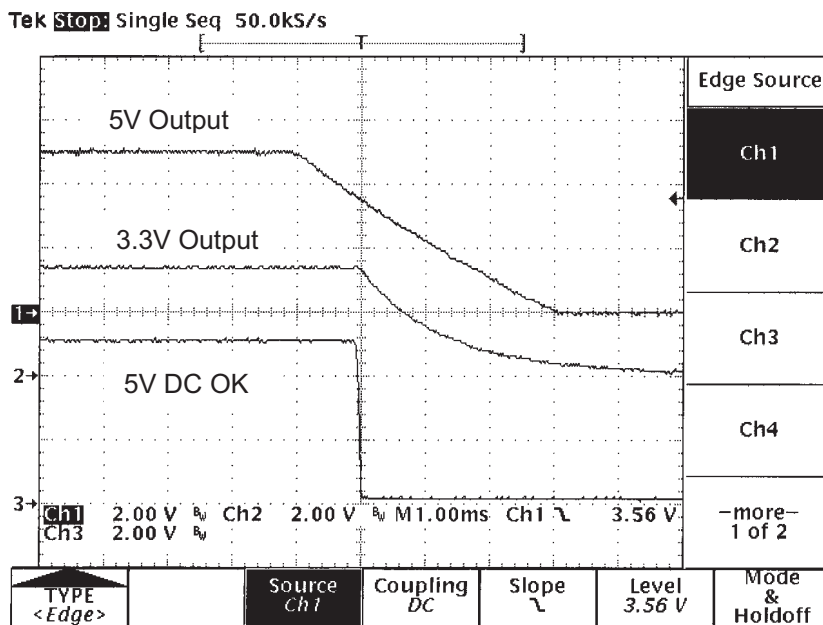

Figure 5. Shutdown Waveforms

Notes

VICOR GLOBAL OFFICES

USA

**Vicor Corporation,
Corporate Headquarters**
25 Frontage Road
Andover, MA 01810
Tel: 800-735-6200,
Tel: 978-470-2900
Fax: 978-475-6715

Vicor Corporation

377 E. Butterfield Road
Suite 201
Lombard, IL 60148
Tel: 630-769-8780
Fax: 630-769-8782

Vicor, Westcor Division

560 Oakmead Parkway
Sunnyvale, CA 94085
Tel: 408-522-5280
Fax: 408-774-5555

EUROPE

Vicor France

Tel: 33-1-3452-1830
Free Phone
France Only:
0800 419 419
Fax: 33-1-3452-2830
Email: vicorfr@vicr.com

Vicor Italy

Tel: +39-02-2247-2326
Free Phone *Italy Only:*
800-899-677
Fax: +39-02-2247-3166
Email: vicorit@vicr.com

Vicor Germany

Tel: +49-89-962439-0
Free Phone
Germany Only:
0800 018 29 18
Fax: +49-89-962439-39
Email: vicorde@vicr.com

Vicor U.K.

Tel: +44-1276-678-222
Free Phone *UK Only:*
0800-980-8427
Fax: +44-1276-681-269
Email: vicoruk@vicr.com

ASIA-PACIFIC

Vicor Hong Kong

Tel: +852-2956-1782
Fax: +852-2956-0782

Vicor Japan Co., Ltd.

Tel: 81-3-5487-3880
Fax: 81-3-5487-3885

For more information about this or other Vicor products, or for assistance with component-based power system design, contact the Vicor office nearest you. Vicor's comprehensive line of power solutions includes modular, high-density DC-DC converters and accessory components, configurable power supplies, and custom power systems. Westcor, a division of Vicor, designs and builds, configurable power supplies incorporating Vicor's high density DC-DC converters and accessory components. **Westcor's product line includes:**

LOPAC FAMILY:

- PFC MicroS
- PFC Micro
- PFC Mini

MEGAPAC FAMILY:

- PFC MegaPAC
- PFC MegaPAC (Low Noise/High Power)
- 4kW MegaPAC
- PFC MegaPAC-EL (Low Noise)
- Mini MegaPAC
- 4kW MegaPAC-EL (Low Noise)
- PFC MegaPAC (High Power)
- Autoranging MegaPAC
- ConverterPACs

OTHERS:

- FlatPAC-EN

Information furnished by Vicor is believed to be accurate and reliable. However, no responsibility is assumed by Vicor for its use. No license is granted by implication or otherwise under any patent or patent rights of Vicor. Vicor components are not designed to be used in applications, such as life support systems, wherein a failure or malfunction could result in injury or death. All sales are subject to Vicor's Terms and Conditions of Sale, which are available upon request.

Specifications are subject to change without notice. *The latest data is available on the Vicor website at vicorpower.com*



www.vicorpower.com