

QPO-1 Output Ripple Attenuation SiP

Description

The QPO-1 output ripple attenuator SiP uses active filtering to reduce power supply output ripple and noise (PARD) over 30 dB from 1 kHz to 500 kHz. The QPO-1 operates over a voltage range from 3 to 30 Vdc and supports load currents as high as 10 A. Output regulation is maintained using remote sensing or the trim input of the power supply. The QPO-1 architecture improves transient response and ensures quiet point-of-load regulation. The QPO-1 reduces the required number of output capacitors to support dynamic loads and will work with most DC-DC converters and switching power supplies.

The scope photo in Figure 2 is an example of the ripple reduction and transient load improvement provided by the QPO-1.

Applications

- Telecom Base Stations
- Point of Load Power Systems
- Sensors Requiring Low Noise Power
- Medical Instrumentation

Features of the QPO-1

- >30 dB PARD attenuation, 1 kHz to 500 kHz
- >20 dB PARD attenuation, 50 Hz to 500 Hz¹
- 10 A rating over a 3-30 Vdc operating range
- Supports precise point-of load regulation
- Up to 99% efficiency with power limit protection
- 25 x 25 x 4.5 mm SiP (System-in-a-Package)
- Low profile LGA package
- User selectable optimization of attenuation, power dissipation & transient load response
- Peak detector function optimizes for ripple amplitude variation automatically
- Improves transient response of most DC-DC converters and power supplies
- Reduces required number of output capacitors to support dynamic loads

Note 1: For off-line supplies 20 dB attenuation can be achieved down to 50 Hz with additional capacitance added from the VREF pin to the REFGND pin.

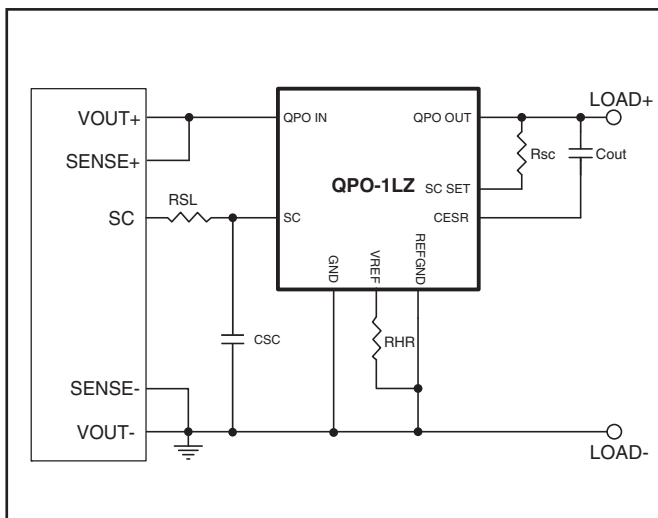

Figure 1 – Typical Application: SC/Trim supports applications that don't require remote sense.

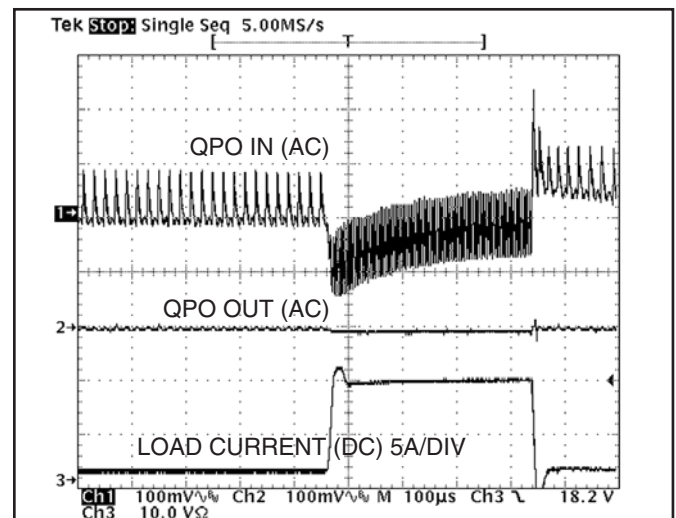

Figure 2 – Typical performance with a 3.3 Volt converter, showing 1 to 10 A load step.

Absolute Maximum Ratings – Exceeding these parameters may result in permanent damage to the product.

Pins	Parameter	Notes	Min	Max	Units
All to GND, REFGND & CESR	Input voltage	Continuous	-0.5	33	Vdc
All to GND, REFGND & CESR	Input voltage	100 ms	-0.5	40	Vdc
QPOin to QPOout	Input to output current	No internal current limit ⁽²⁾		15	Adc
Package	Power dissipation	10 Adc & Vhr = 375 mV		4	W
Package	Operating temperature	PCB to QPO Interface	-40	100	°C
Package	Thermal resistance	Free Air		50	°C/W
Package	Thermal resistance	PCB Layout Figs. 14 & 15		12	°C/W
Package	Storage temperature		-40	125	°C
Package	Re-flow temperature	20 second exposure @ ⁽⁴⁾		212	°C
All Pins	ESD			±4	kV

Electrical Characteristics – Parameter limits apply over the operating temp. range unless otherwise noted.

Symbol	Parameter	Notes	Min	Max	Units
Iload	Operating load current range	Note 3	0.03	10	Adc
Vout	Output voltage range	Continuous	3.0	30	Vdc
Vhr	Headroom voltage range	See applications detail for setting	225	525	mVdc
Vtout	Transient response $\Delta I_{out} = 2A$ voltage drop $\Delta I_{out} = 10A$	Vhr = 375 mV @ 100 mA Cin = 200 μF Vhr = 375 mV @ 100 mA Cin = 1500 μF		50	mVdc
Vnout	Output noise	Input PARD = 100 mVpp 50-500 kHz Cvref = 25 μF		10	mVpp
Iscout	SC output current accuracy	See applications detail for setting	-1	+1	%
Iingnd	Input bias current	Input current from QPO IN to Gnd		60	mA

Note 2: User must protect load path and limit the steady state load current to be less than the absolute maximum of 15 Amps.

Note 3: User must provide a minimum load current of greater than 30 mA at the output of the QPO-1. With no load QPOout is greater than QPOin.

Note 4: RoHS compliant product maximum peak temperature is 245°C for 20 seconds.

Pad Descriptions

Pad Number	Name	Description
1, 19, 20	GND	Input ground
2	SLOPE ADJ	Rsa resistor connection allows setting of the slope of headroom voltage vs. load (mV/A)
3	VREF	Input to the active filter, setting the output voltage at the QPOOUT pins
4	REFGND	Ground reference for the VREF pin (critical low noise connection)
5	CESR	Output compensation return node to an internal resistor
6	SC SET	Rsc resistor connection allows setting of the converter output using converter SC or trim control
7, 8, 9, 10, 17	QPOOUT	Output pins
11, 12, 13, 14, 18	QPOIN	Input pins (critical thermal path to remove heat from the package, see PCB suggested layout Fig.15)
15	PEAK IN	Peak Detector Input
16	SC	Output current source of the SC SET function used to drive the SC/Trim pin of the power source

LGA Pattern

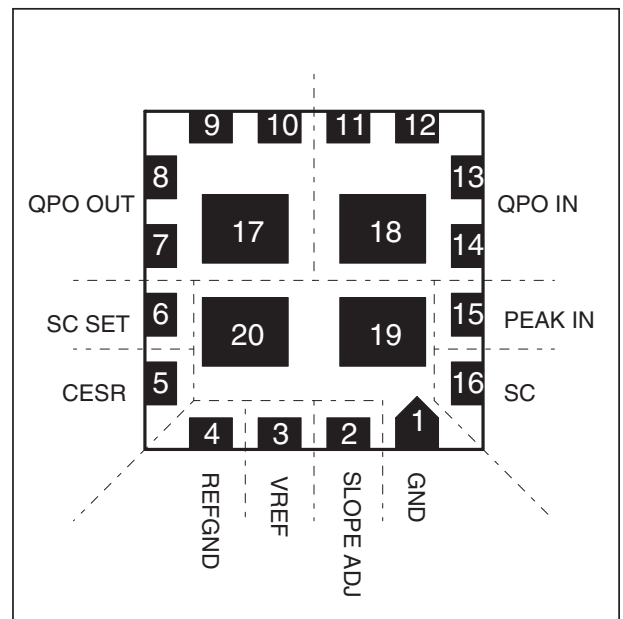

Product Highlights

Picor's QPO-1 output ripple attenuator System-in-a-Package (SiP) provides the user with features that can optimize the performance of the product to meet their system needs. The QPO-1 uses active filtering to achieve greater than 30 dB attenuation of periodic and random deviation (PARD) over the frequency range of 1 kHz to 500 kHz. For converters running off-line, with greater low frequency output ripple, attenuation can be extended to be greater than 20 dB at 50 Hz by connecting a 25 μ F capacitor between the VREF and REFGND pins.

The QPO-1 operates over an output voltage range of 3 to 30 Vdc and is compatible with most switching power supplies and DC-DC converters. Remote Sense or SC/Trim can be selected to maintain output voltage regulation at the load. The SC/Trim feature will adjust the converter output voltage to compensate the headroom drop of the filter if remote sense is not available or not preferred. The SC function works with converters that have a positive reference type trim adjustment feature.

The QPO-1 can be used in an open loop configuration without remote sense or SC/trim. In this mode of operation the QPO-1 will still provide greater than 30 dB of ripple and noise attenuation but DC errors will not be corrected once the converter and headroom voltages are set, resulting in reduced load regulation and transient performance.

The QPO-1's closed loop architecture greatly improves load transient response of the converter while ensuring steady-state precise point of load voltage regulation. The headroom setting of the QPO-1 filter dramatically reduces the capacitance needed at the converter output to provide equivalent transient performance and ripple reduction. Figure 2 demonstrates how the QPO-1 can be an ideal solution for noise sensitive applications providing ripple and noise reduction and improved output regulation with high transient loads.

Functional Description

The QPO-1 is an active power filter that provides differential attenuation of power supply output ripple and noise (PARD) when inserted between the output of the supply and the load. The core of the design is a high-bandwidth closed loop circuit that forces the QPOOUT pins to be equal to the VREF pin. The VREF pin is a filtered ratio metric representation of the input voltage that is determined by the value of the R_{HR} . The voltage difference between the input to the QPO-1 and VREF pin is defined as the headroom voltage V_{hr} . The filter time constant of the VREF pin determines the low frequency attenuation response of the QPO-1. The high frequency attenuation response is determined by the roll-off characteristics of the active loop.

The QPO-1 has a current sensing function that creates a voltage at the **Slope Adjust** pin that is proportional with the load current. This feature can be used to improve the efficiency of the filter when supply ripple amplitude reduces with increasing load as with variable frequency DC-DC converters. By selecting the appropriate R_{sa} resistor value, the slope of the headroom reduction versus load current can be set. Reducing the headroom voltage by the amount set by the R_{sa} value results in reduced power dissipation in the QPO-1 when compared to a fixed headroom setting. The current sensing function also provides a power limit function that forces the filter to its minimum possible loss if the load current approaches 15 Amps, providing a power fold-back limiting feature.

A **Peak Detection** function adds the input peak of the ripple voltage to the headroom voltage. The QPO-1 will track the input ripple, adjusting the headroom within the dynamic range of the filter as the peak voltage of the ripple changes. The peak of the ripple will automatically be summed with the DC setting of the headroom voltage. The peak detect function, in combination with the slope-adjust function, allows the user to optimize the initial headroom voltage and overall efficiency required for their specific application.

Application of the QPO-1

The configurations for remote sense or SC/Trim are shown in Figures 3 and 4. In either configuration, the source output voltage will increase to accommodate the headroom setting of the QPO-1 to maintain the load voltage at the required level. The user must decide on the control mode to be used and select the appropriate circuit configuration. Designers must consider the effect of headroom setting and power dissipation versus attenuation. The majority of the power dissipation of the QPO-1 is the product of the headroom voltage times the average load current and must always be less than 4 Watts. The dynamic headroom range of the QPO-1 is 225 mV to 525 mV as long as the 4 W maximum power rating is not exceeded. It is important that the user understands the range of expected ripple and transient performance of their power source to properly bias and utilize the QPO-1 features. The objective is to maximize attenuation and minimize dissipation while staying within the QPO-1 dynamic operating range. Knowing the worst case maximum steady state ripple, output impedance and transient response time of the power source will determine the minimum required headroom of the QPO-1 set by value of R_{HR} .

In the case where remote sense or SC/Trim use is not possible, the QPO-1 can still be used to provide PARD attenuation. Voltage at the load will be reduced by headroom voltage set by R_{HR} in the initial design. Trimming the supply output above nominal by an amount equal to the headroom voltage will compensate for the QPO-1 headroom drop for a given load. Further DC correction for load variation at the QPO-1 output will occur only within the supply control loop and the QPO-1 output will be controlled to the voltage present at the VREF pin in this open loop filter configuration.

If the peak detector option is enabled, the headroom will automatically increase by the peak of the ripple amplitude from the setting determined by R_{HR} . The peak detector option makes the initial headroom setting less critical because the headroom and dynamic range will track the peak of the ripple while maintaining the required QPO-1 biasing to actively attenuate the ripple. Caution must be taken to ensure that the added peak detection headroom does not cause power dissipation to exceed 4 Watts. The time constant of the peak detect feature is approximately 30 ms in response to ripple amplitude changes. Connecting the PEAKIN pin to the QPOIN pins enables the Peak detect feature. Putting a small RC filter at the PEAKIN pin as shown in Figure 5, disables the feature. The PEAKIN pin must be connected in either configuration.

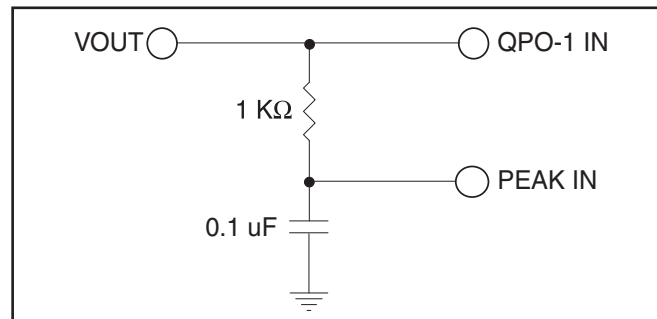

Figure 5 – Peak detect disable circuit.

The optional slope adjust feature reduces the headroom in proportion to load current. Slope adjust reduces the maximum ripple range if the user has a converter where ripple amplitude decreases with increasing load current. The slope adjust feature is enabled by selecting the proper Rsa value and is disabled using Rsa=100 Kohms.

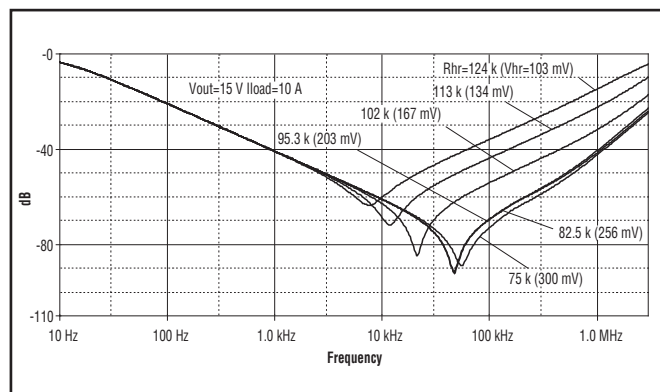

Figure 6 – Attenuation for different headroom settings with value of R_{HR} and (V_{hr}) .

Figure 6 shows the headroom versus attenuation relationship of the QPO-1 for a 15 Volt output. This relationship is relatively constant over the full output voltage rating of the QPO-1 so Figure 6 can be used to select headroom voltage for any converter output voltage in the 3 to 30 Volt range of the QPO-1.

The final headroom voltage selection should be based on the maximum expected ripple, desired attenuation and transient response needed. Formulas for the slope adjust Rsa and Rsc values will be provided in their respective sections. **The headroom adjustment shown in Figures 6 and 7 show increasing headroom voltage will increase the attenuation over the range of 10 kHz to over 1 Mhz.**

Figure 7 is the attenuation with a 25 μ F capacitor connected between the VREF and REFGND pins, increasing the low frequency attenuation by roughly 10 dB. The R_{HR} resistor value is determined by using the following formula.

$$R_{HR} = \frac{QPO_{out}}{V_{HR}} * 2.5 \text{ k}\Omega$$

where; R_{HR} = headroom setting resistor value,
 QPO_{out} = the expected voltage on the QPO's output,
 V_{hr} = the target headroom voltage for desired range of attenuation.

To ensure sufficient headroom during a transient load change additional headroom voltage may be required to provide margin and cover the instantaneous drop in the converter output. In the example shown in Figure 2, an additional 75 mV was included with the headroom value selected from the graph in Figure 6 to cover the transient drop-in the supply output during the 10 Amp step.

In this example 300 mV was chosen as a reasonable value to set the headroom (V_{hr}) since it is at the point of diminishing returns based on the attenuation graph in Figure 6. To stay within the dynamic range required by the active loop during the load transient, a total of 375 mV was used in the R_{HR} formula to determine the value of the R_{HR} resistor. The peak detector will dynamically add 30 mV (derived from the 60 mV peak to peak input ripple) to the static headroom setting, providing the total dynamic headroom of approximately 405 mV with the detector enabled.

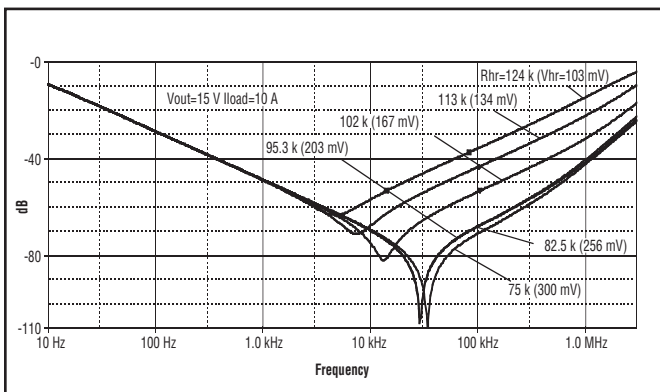

Figure 7 – Attenuation at different headroom settings with 25 μ F capacitor connected to V_{ref} .

The input capacitance to the QPO-1 will provide the transient load current, keeping the QPO_{OUT} at the V_{REF} voltage until the converter loop responds to regulate the load. During this time, the transient load current capability can be approximated by the formula below. The capacitance, C_{in} may be within the power supply that is used or supplemented by external capacitance. The power

supply's sensitivity to additional output capacitance and stability must be understood before additional capacitance is added for enhancement of transient performance.

$$\Delta I = \frac{V_{HR}}{2Tr} * C_{IN}$$

where; C_{IN} = Input capacitance (assuming low ESR/ceramic type) at the QPO-1 input

ΔI = Step load current change

Tr = Converter response time

V_{HR} = Headroom voltage

The output voltage drop, V , for a given supply during a transient load step will be reduced at the output of the QPO-1, effectively multiplying the C_{in} capacitance by the ratio of $V_{in}/\Delta V_{out}$ which is typically greater than a factor of 10.

The user must be aware of the source's over-voltage set point and not create a headroom voltage that will cause an OVP shutdown condition. It is recommended that the QPO-1 be used with power supplies running at the preset voltages or in a trimmed down configuration.

In low voltage applications (<12 V), it may be required to use the C_{sc} capacitor as shown in Figures 3 and 4. This creates a soft start of the source preventing the output from tripping the over voltage function before the QPO-1 output reaches regulation. The QPO-1 ramp-up time is typically 5 to 10 ms. The C_{sc} value will be supply dependent but is typically around 1 to 10 μ F. Remote sensing applications below 5 Volts may also require the PFET shown as Q in Figure 3 for start up. To prevent the over voltage shut down, this device will close the sense loop around the converter until the QPO_{out} is within the V_t of the FET. Use a logic level low voltage PFET like the IRLML6401 or equivalent.

Headroom Slope Adjustment

The headroom slope allows more headroom at lighter loads while keeping power dissipation in the QPO-1 relatively constant over the full load range. The slope of this curve is set by the slope adjust resistor R_{sa} . The headroom voltage in Figure 8 has been reduced by 150 mV over the range of 1 to 10 A for a typical range of R_{HR} values with 15 Volts output. The headroom setting R_{HR} was selected at the minimum load condition, 30 mA, while enabling the slope function using an R_{sa} value of 8.2 k.

The slope adjust feature improves the QPO-1 efficiency when using variable frequency switching power supplies that have decreasing ripple with increasing load current.

The slope adjust feature can be set to zero providing relatively constant headroom versus load using an Rsa of 100 k. The user can optimize performance based on the expected variation in load current and the desired power dissipation range. The following formula should be used to calculate the Rsa value for the desired headroom versus current slope. If the peak detector is enabled, the peak of the ripple will be added back to the headroom at a given load condition.

$$R_{SA} = 0.05(V/A) * \frac{\Delta I_{OUT}}{\Delta V_{HR}} * 2.5 \text{ k}\Omega$$

where; I_{out} = Maximum load current change

V_{HR} = Change in headroom desired over the load range

RSA = Slope adjust resistor value

Example: For a 5 A maximum load and a 150 mV reduction in headroom.

$$R_{SA} = 0.05(V/I) * \frac{5 \text{ A}}{0.15 \text{ V}} * 2.5 \text{ k}\Omega = 4.167 \text{ k}\Omega$$

Figures 9 and 10 demonstrate the attenuation versus power dissipation relationship with different headroom resistor values with corresponding increasing power dissipation at a fixed 10A load. The low frequency attenuation is flat with changing headroom as indicated by the 50Hz line. The active attenuation is dependent on the headroom voltage and correlates to the attenuation curves presented previously.

Figure 10 shows the increase in attenuation that can be gained by using the slope adjust feature setting higher headroom at lower loads while limiting the power dissipation with reduced headroom at higher loads staying within the 4 Watt limitation of the package. As stated previously this will also increase the transient capability with a load step providing more delta voltage across the filter at lower loads.

Note 4: When applicable, consider the equivalent impedance of the SC/Trim pin after a trim has been made to the supply. Use the power supply manufacturer's trim procedure by connecting a resistor from the SC/Trim pin as directed.

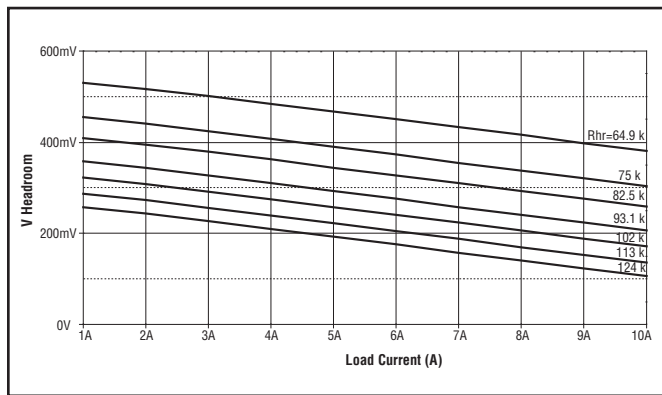

Figure 8 - Effect of slope adjust on headroom value with increasing current and RSA = 8.2 k.

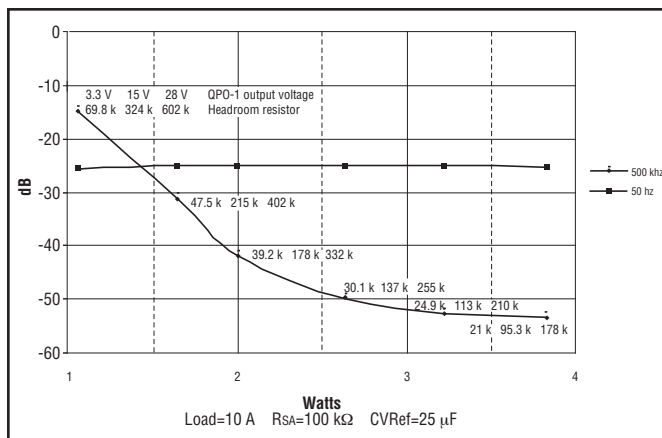

Figure 9 - Attenuation vs. power dissipation without slope adjust.

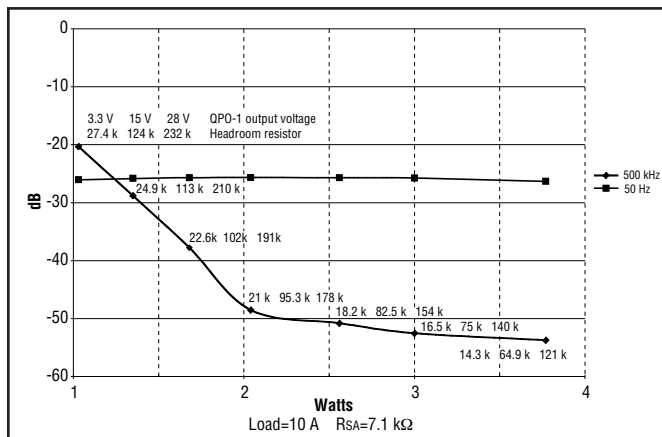

Figure 10 - Attenuation vs. power dissipation with slope adjust.

SC/Trim Adjustment

The RSC resistor is tied between QPOOUT and SCSET pin and controls the correction current used to trim up the converter to compensate for the headroom voltage drop of the QPO-1. The value for the SCset resistor is calculated by the following equation:

$$R_{SC} = \frac{R_{IN} * V_{OUT}}{\Delta V_{RPT}}$$

where; Rsc is the resistor value, setting the SC correction current

R_{IN} is the input resistance of the SC or TRIM input of the converter ⁴

V_{OUT} is the desired QPO-1 output voltage,

V_{rpt} is the pre-trimmed reference of the SC or TRIM.

This feature can be used in conjunction with initially trimming a supply up or down. Be careful not to trip the OVP feature if trimming up the converter.

When using the QPO as shown in figure 4 the CSC capacitor creates a soft starting of the headroom correction current being sourced into the SC/Trim input of the converter, preventing the output from tripping the over voltage function while the QPO-1 output reaches regulation. The QPO-1 ramp up time is typically 5 to 10 milliseconds. The CSC value will be supply dependent but is typically around 1 to 10µF. The RSL resistor provides a means to isolate the SC/Trim pin of the converter from CSC as well as limit the correction current to a level below what will cause an OVP trip condition during start up. The compliance of the SC output current source is QPOIN plus 8 volts so the RSL formula below can be used to limit the worst-case correction current below the maximum trim up specification of the converter being used. Note the correction current set by RSC must always be lower than the ISCMAX current after the start-up settling time interval for proper headroom correction. ISCMAX is the maximum current that can be sourced into a converter's trim pin and not cause an over-voltage fault. For VICOR converters that's typically 123 µA.

$$R_{SL} = \frac{QPO_{IN} + 8 V}{I_{SCMAX}}$$

Another way to avoid tripping the OVP function in some applications is to use the circuit shown in *Figure 11*. The PFET(Q1) connects VREF to QPOIN during start up. Until Csu charges up and turns off Q1, the QPO will have zero headroom voltage (QPO IN = QPO OUT). When Q1 turns off the QPO will establish the programmed headroom voltage set by R_{HR}.

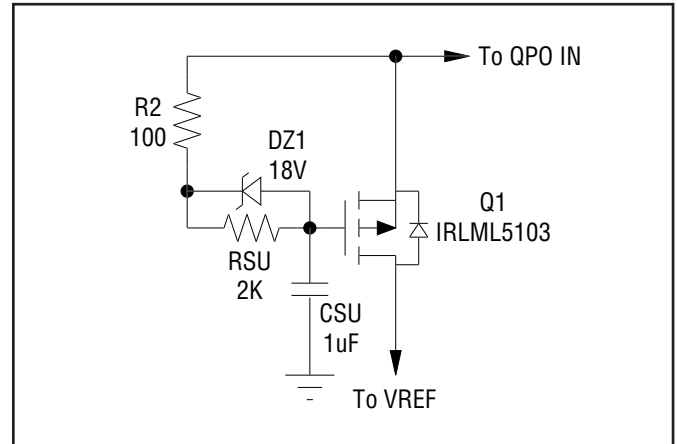

Figure 11 - Zero Headroom Start-up Circuit.

The active loop performance of the QPO-1 has been optimized to provide adequate phase margin over a worst case load impedance range. Loading the output of the QPO-1 directly with low-ESR ceramic capacitors will significantly reduce the phase margin and is not recommended. The effects of the typical distributed inductance of the load path will mitigate the reduction in phase margin when low ESR ceramic capacitors are dispersed along the load path.

The lead inductance from the output of the QPO-1 to the load should be minimized; this inductance will cause ringing proportional to the inductance and the load change (di/dt) of the transient load current. Low ESR capacitors may have to be placed at the load when there are long leads between the QPO-1 and load. The rate of load change must be less than 1A/µS to minimize excessive voltage ringing during the di/dt.

For applications requiring quiet power on split supply rails with a common, connect the QPOs and converters as shown in Figure 12. This schematic shows the QPO's configured in the open loop configuration. If the application requires tighter load regulation, add the SC/TRIM or remote sense circuitry to each QPO as shown in Figures 3 and 4. For quieting a negative supply rail use the circuit in the lower half of the schematic and leave the plus (+) output of the supply floating.

The following is a summary of typical configurations that a user can select for optimization of the QPO-1.

- No slope adjust, no peak detect, fixed headroom, attenuation vs headroom graph in Fig. 6 and 7 apply
- No slope adjust, peak detector enabled, headroom will increase by the peak of the ripple amplitude
- Slope adjust enabled, no peak detect, headroom will decrease with the increase in load current
- Slope adjust enabled, peak detector enabled, headroom will vary with ripple amplitude and load variations

The attributes of these features have been explained in this data sheet. The optimum use of them requires an understanding of the characteristics of the power supply to be filtered. If the characteristics are unknown it is recommended to use the first configuration listed above and set the headroom voltage at 375 mV.

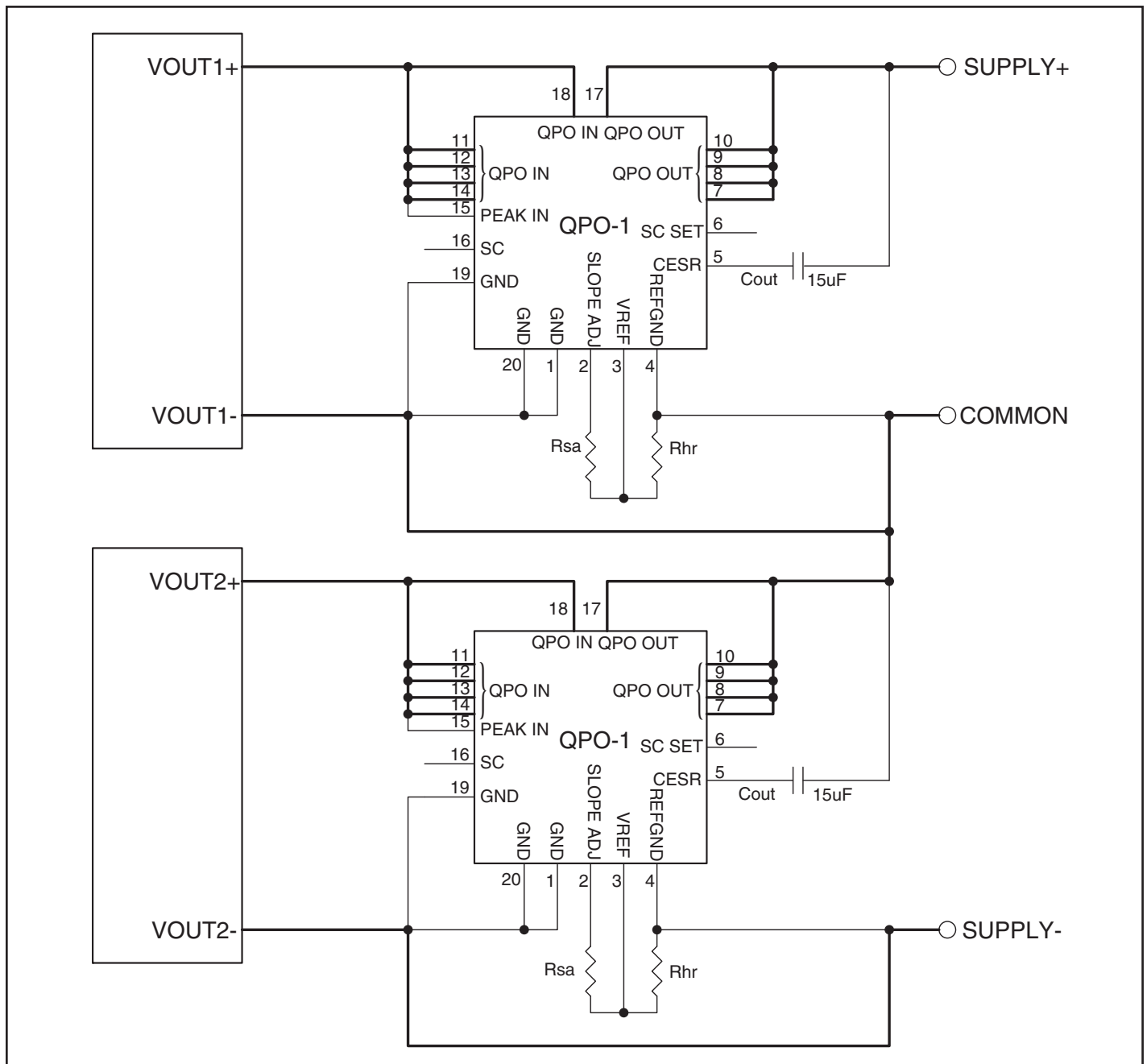

Figure 12- Schematic for +/- supply application. Circuit shown is for an open loop configuration. See text and schematic showing SC/Trim and remote sense application if required. Dark lines show high-current path.

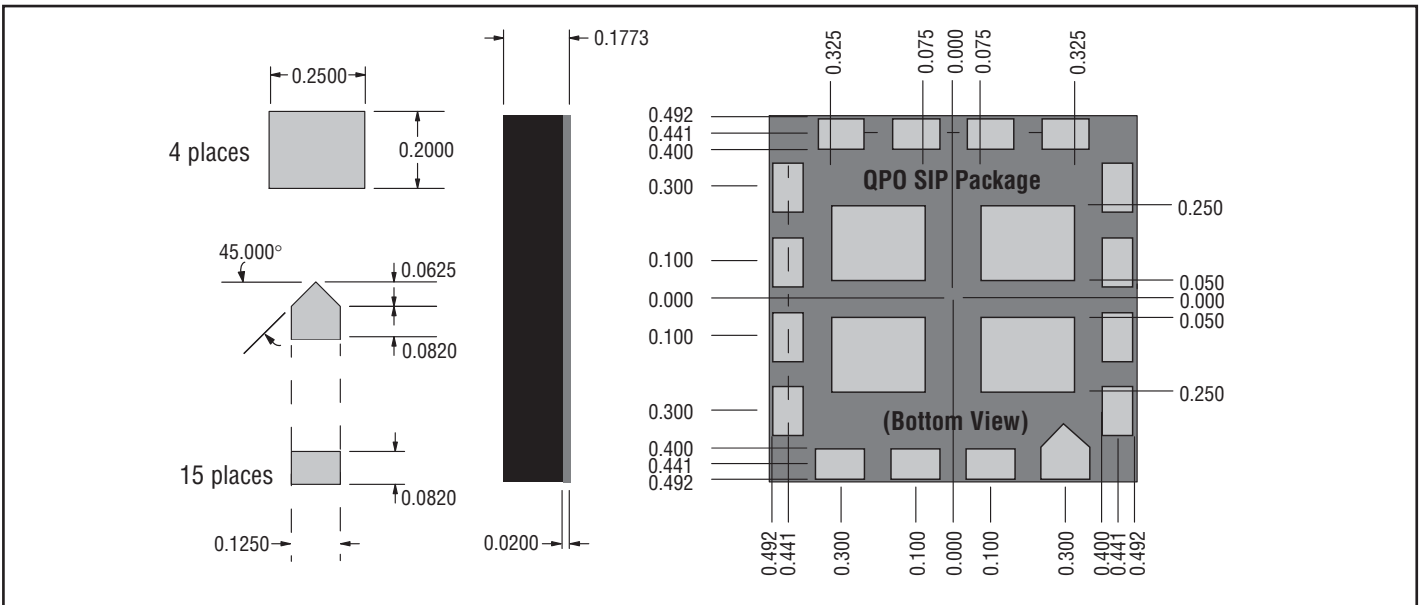

Figure 13 - Package dimension drawing (dimensions in inches)

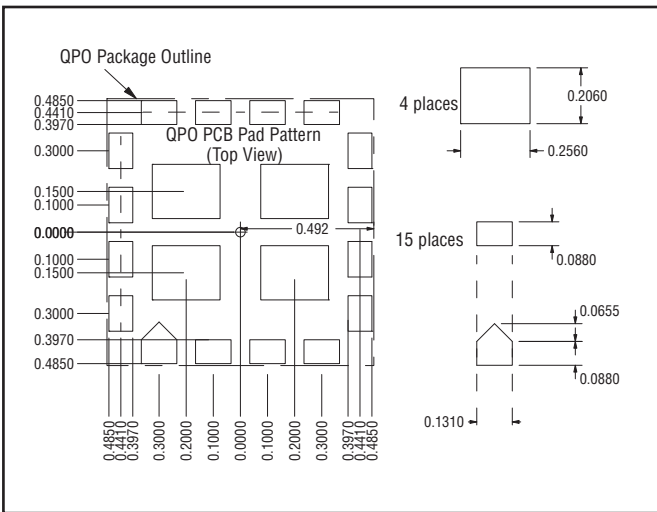

Figure 14 - LAND GRID ARRAY PCB Solder Mask Openings (dimensions in inches)

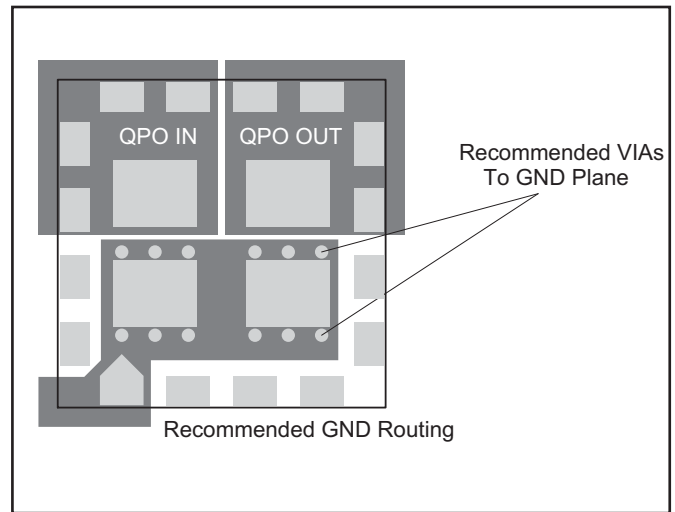

Figure 15 - Recommended copper pattern for LGA mounting showing QPO pads and minimum copper landing. Pattern should be on 2 oz. copper with vias, placed outside of device pad solder mask openings, used to connect to internal layers (if required).

Post Solder Cleaning

Picor lidded QP SIPs are not hermetically sealed and must not be exposed to liquid, including but not limited to cleaning solvents, aqueous washing solutions or pressurized sprays.

When soldering, it is recommended that no-clean flux solder be used, as this will insure that potentially corrosive mobile ions will not remain on, around, or under the module following the soldering process.

For applications requiring water wash compatibility the “-01” open frame version should be used.

Ordering Information

Part Number	Description
QPO-1LZ	QPO-1 LGA Package, RoHS Compliant
QPO-1LZ-01	QPO-1 LGA, RoHS Compliant Open Frame Package

Vicor's comprehensive line of power solutions includes high-density AC-DC & DC-DC modules and accessory components, fully configurable AC-DC & DC-DC power supplies, and complete custom power systems.

Information furnished by Vicor is believed to be accurate and reliable. However, no responsibility is assumed by Vicor for its use. No license is granted by implication or otherwise under any patent or patent rights of Vicor. Vicor components are not designed to be used in applications, such as life support systems, wherein a failure or malfunction could result in injury or death. All sales are subject to Vicor's Terms and Conditions of Sale, which are available upon request.

Specifications are subject to change without notice.



Vicor Corporation
25 Frontage Road
Andover, MA, USA 01810
Tel: 800-735-6200
Fax: 978-475-6715

Email
Vicor Express: vicorexp@vicr.com
Technical Support: apps@vicr.com